

Effects of FCL on Operation of SEF-DFIG in wind turbine systems During Grid Fault

Mehrdad Moradi

Department of Electrical Engineering, Shahed University
and Iran Grid Management Company
Tehran, Iran
mehrdad_moradi4030@yahoo.com

Mohamad Reza Besmi, Aref Doroudi

Department of Electrical Engineering
Shahed University
Tehran, Iran
besmiqw@yahoo.com, doroudi@gmail.com

Mehrdad Fazli

Iran Grid Management Company
Tehran, Iran
mehrdadfazli@gmail.com

Abstract—During last decade, the concept of a variable speed wind turbine equipped with doubly fed induction generator (DFIG) has received increasing attention due to its noticeable advantages over other wind turbine generator concepts. New configuration of DFIG is single external feeding of DFIG (SEF-DFIG) where a rotor side converter (RSC) replaces the back to back variable frequency converter (VFC) in the conventional DFIG. The main issue of wind turbines that equipped DFIG and SEF-DFIG is the grid faults or low voltage ride through capability. In this paper, a new solution for uninterrupted operation of wind turbine driving a SEF-DFIG has been proposed during fault condition in the grid. A fault current limiter (FCL) is placed in series with the rotor circuit. During fault condition FCL enters a impedance in the rotor circuit to inhibit increasing of current in the rotor circuit. When the fault is cleared the FCL bypasses the impedance. A static synchronous compensator (STATCOM) has been applied for supplying required reactive power in faults and steady states. Capability and modeling accuracy of the proposed method confirmed with simulating a sample power system in PSCAD/EMTDC software.

Keywords—doubly fed induction generator (DFIG); single external feeding doubly fed induction generator (SEF-DFIG); fault current limiter (FCL); static synchronous compensator (STATCOM); wind turbine

I. INTRODUCTION

The global anxiety about environmentally pollutions besides the concerns about lacking energy resources, have led to intensify applying renewable energy resources with demand technology. More than 35 GW of new wind power capacity was brought online in 2013, but this was a sharp decline in comparison 2012. The new global total at the end of 2013 was 318105 MW representing cumulative market growth of more than 12.5 percent [1].

Wind turbines can be categorized two main groups: fixed-speed wind turbines and variable-speed wind turbines. Although simple and robust, fixed speed turbines suffer from

the unavoidable disadvantage that they cannot operate efficiently capture the energy in the wind [2]. This is because they can only operate at one speed and wind speed is variable. For each wind speed there is a certain turbine shaft speed that produces maximum power. A fixed speed turbine can only operate at maximum aerodynamic efficiency for one particular wind speed. As the wind varies from this speed the efficiency of the wind turbine is reduced. Therefore to capture the maximum amount of the power from the wind, the turbine must be made to operate at variable speeds and to follow the curve of maximum power extraction.

During last decade, the concept of a variable speed wind turbine equipped with doubly fed induction generator (DFIG) has received increasing attention due to its noticeable advantages over other wind turbine generator concepts. In DFIG concept, a wound rotor induction generator connected to the power system via its stator terminals. On the other hand the rotor connected to the power system means the ac/dc/ ac partially rated variable frequency converter (VFC), which VFC rated is 25-30 percent of DFIG nominal power. VFC includes a grid side converter (GSC) and rotor side converter (RSC) that are connected back to back by a dc capacitor. However, it is a drawback that this system requires slip rings and brushes, which increase both establishment and maintenance cost [3]. Fig.1 shows DFIG configuration.

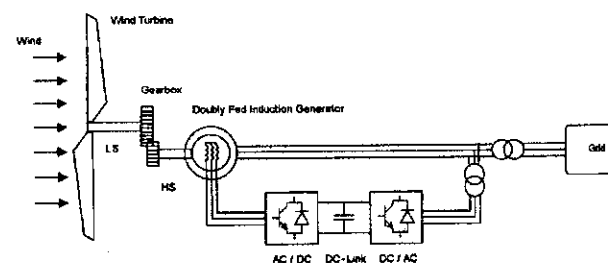

Fig. 1. Configuration of DFIG wind turbine

Effects of FCL on Operation of SEF-DFIG in wind turbine systems During Grid Fault

Mehrdad Moradi

Department of Electrical Engineering, Shahed University
and Iran Grid Management Company
Tehran, Iran
mehrdad_moradi4030@yahoo.com

Mohamad Reza Besmi, Aref Doroudi

Department of Electrical Engineering
Shahed University
Tehran, Iran
besmiqw@yahoo.com, doroudi@gmail.com

Mehrdad Fazli

Iran Grid Management Company
Tehran, Iran
mehrdadfazli@gmail.com

Abstract—During last decade, the concept of a variable speed wind turbine equipped with doubly fed induction generator (DFIG) has received increasing attention due to its noticeable advantages over other wind turbine generator concepts. New configuration of DFIG is single external feeding of DFIG (SEF-DFIG) where a rotor side converter (RSC) replaces the back to back variable frequency converter (VFC) in the conventional DFIG. The main issue of wind turbines that equipped DFIG and SEF-DFIG is the grid faults or low voltage ride through capability. In this paper, a new solution for uninterrupted operation of wind turbine driving a SEF-DFIG has been proposed during fault condition in the grid. A fault current limiter (FCL) is placed in series with the rotor circuit. During fault condition FCL enters a impedance in the rotor circuit to inhibit increasing of current in the rotor circuit. When the fault is cleared the FCL bypasses the impedance. A static synchronous compensator (STATCOM) has been applied for supplying required reactive power in faults and steady states. Capability and modeling accuracy of the proposed method confirmed with simulating a sample power system in PSCAD/EMTDC software.

Keywords—doubly fed induction generator (DFIG); single external feeding doubly fed induction generator (SEF-DFIG); fault current limiter (FCL); static synchronous compensator (STATCOM); wind turbine

I. INTRODUCTION

The global anxiety about environmentally pollutions besides the concerns about lacking energy resources, have led to intensify applying renewable energy resources with demand technology. More than 35 GW of new wind power capacity was brought online in 2013, but this was a sharp decline in comparison 2012. The new global total at the end of 2013 was 318105 MW representing cumulative market growth of more than 12.5 percent [1].

Wind turbines can be categorized two main groups: fixed-speed wind turbines and variable-speed wind turbines. Although simple and robust, fixed speed turbines suffer from

the unavoidable disadvantage that they cannot operate efficiently capture the energy in the wind [2]. This is because they can only operate at one speed and wind speed is variable. For each wind speed there is a certain turbine shaft speed that produces maximum power. A fixed speed turbine can only operate at maximum aerodynamic efficiency for one particular wind speed. As the wind varies from this speed the efficiency of the wind turbine is reduced. Therefore to capture the maximum amount of the power from the wind, the turbine must be made to operate at variable speeds and to follow the curve of maximum power extraction.

During last decade, the concept of a variable speed wind turbine equipped with doubly fed induction generator (DFIG) has received increasing attention due to its noticeable advantages over other wind turbine generator concepts. In DFIG concept, a wound rotor induction generator connected to the power system via its stator terminals. On the other hand the rotor connected to the power system means the ac/dc/ ac partially rated variable frequency converter (VFC), which VFC rated is 25-30 percent of DFIG nominal power. VFC includes a grid side converter (GSC) and rotor side converter (RSC) that are connected back to back by a dc capacitor. However, it is a drawback that this system requires slip rings and brushes, which increase both establishment and maintenance cost [3]. Fig.1 shows DFIG configuration.

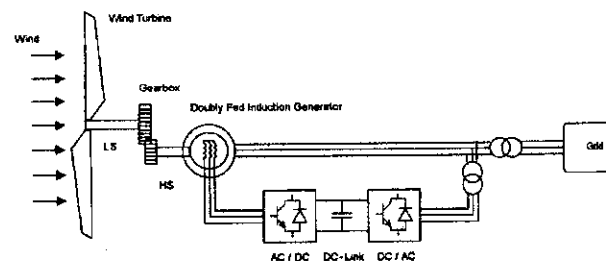

Fig. 1. Configuration of DFIG wind turbine

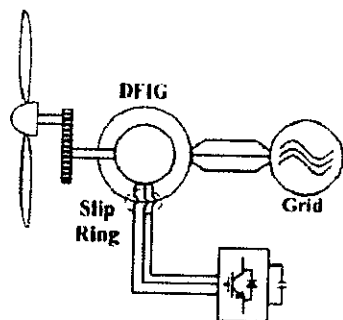

Fig. 2. Configuration of SEF-DFIG wind turbine

DFIGs has established itself as the standard generator configuration used by industry. Despite the recent trend towards permanent magnet generator solutions, the DFIG remains a relevant and important technology for the wind industry, accounting for roughly 50 percent of the installed capacity in 2011 [4]. Three of top six turbine manufactures, sinovel, gold wind and GE, offer a doubly fed solution.

In [5], proposed a new configuration of single external feeding of DFIG (SEF-DFIG) where a rotor side converter (RSC) replaces the back to back VFC in the conventional DFIG. Fig.2 represent the SEF-DFIG concept.

Compared to the conventional DFIG, the SEF-DFIG requires only one inverter in the rotor side and the power consumed in the inverter is supplied not from the grid but through the stator.

The rotor side inverter is manipulated in order to control both shaft and the dc link voltage of the inverter simultaneously.

The dc link voltage level for these is not required to be fixed, so the dc link voltage level can be changed as operating point varies [5]. SEF-DFIG can control the power and wind generator speed as in the conventional DFIG, it can operate in variable speed mode and regulate the generated power in various wind speed. Eliminating the grid side converter and filters, can reduce the systems cost and complexity.

The basic worriment of wind turbines that coupled with DFIG and SEF-DFIG is in their operation process when faults occur in the grid. Through each power system, the faults can lead to voltage dip at the connection point of wind turbine even if they are far from turbine location. The dip that created in the grid voltage results increasing of the current in the stator windings of DFIG and SEF-DFIG. This increased current will also flow in the circuit of rotor, because of magnetic coupling feature between stator and rotor of DFIG and SEF-DFIG. Therefore, the power electronic converter is also affected by this superabundant current. If the power rating of the VFC is more than 25 to 30 percent of the induction generator power rating, this current can lead to destruction of the converter. Hence, the main issue of wind turbines that equipped with DFIG and SEF-DFIG is the grid fault or low voltage ride through capability. Many efforts has been done for solving this issue and several methods have been suggested through

technical papers and researches [6], [7], [8], [9], [10], [11]. One of the methods solves the problem by blocking the RSC and short-circuiting the circuit of the rotor with applying a crow-bar circuit for protection of Converter from over current in the rotor circuit [6]. The wind turbine generator (WTG) continues operating to produce active power and the GSC can be set for voltage and reactive power control. When the occurred fault has been cleared beside reestablishment of voltage and frequency in the power grid, the RSC restarts and the WTG returns to normal operation mode. In a case that the power network is weak and during a grid fault, the GSC cannot supply sufficient reactive power for voltage support due to its minor power capacity. So, probably the voltage collapse can be occur. Therefore, the RSC cannot restart and the WTG will be disconnected from the grid. In [7], the authors proposed using a static synchronous compensator (STATCOM) to support the uninterrupted operation of wind farm that is equipped with DFIGs during grid faults. With these solutions [6], [7], it can be resulted that when the fault is cleared resuming normal operation of WTG without transient mode is not quite feasible. Thyristor-controlled resistors have been considered as a means to suppress short circuit currents [8]. The second solution has been presented is improving the control scheme of the RSC. To enhance the grid-fault ride through capability of the DFIG wind turbine, by a non linear controller and a fuzzy controller that have been mentioned respectively in [9] and [10] to control the RSC. In [11], solution for uninterrupted operation of wind turbine equipped with doubly fed induction generator proposed during fault condition in the grid. A fault current limiter (FCL) is placed in the rotor circuit. When the fault occurs in the network, the gate turn-off thyristors (GTOs) of FCL turns off and enters a impedance in the rotor circuit to inhibit increasing of current in the rotor circuit. When the fault is cleared, the GTOs of FCL turns on and bypass the impedance out of rotor circuit. The advantage of this method is that generator and power electronic converter stay connected to the network, synchronous operation of WTG can be provided significantly during fault condition and normal operation can be continued immediately after fault clearance.

In this paper, a new solution for uninterrupted operation of wind turbine equipped with SEF-DFIG has been proposed. A fault current limiter (FCL) is placed in the rotor circuit as same that in [11] applied for DFIG. When the fault occurs in the network, the gate turn-off thyristors (GTOs) of FCL turns off and enters a huge impedance in the rotor circuit to inhibit increasing of current in the rotor circuit. When the fault is cleared, the GTOs of FCL turns on and bypass the impedance out of rotor circuit. On the other hand, in this paper has been used from a static synchronous compensator (STATCOM) for supplying required reactive power in steady and occurring fault states. Applicability and accuracy of this method will be confirmed by simulating a sample power system in PSCAD/EMTDC software.

II. SAMPLE POWER SYSTEM

Generally, a large wind farm consists of hundred individual wind turbines. It has been proposed in [6] that with using well-tuned converter, no mutual interaction will be occurred between wind turbines of a wind farm. Therefore, in this paper,

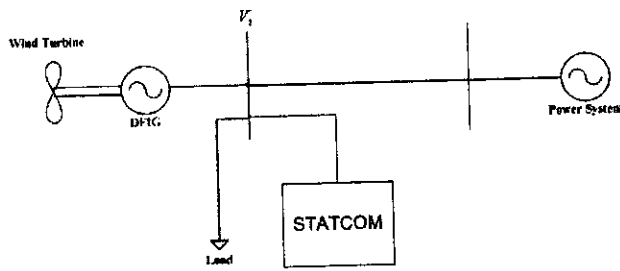

Fig. 3. Single line diagram of the sample power system

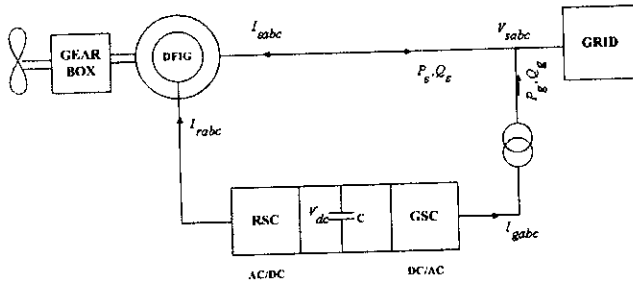

Fig. 4. Configuration of DFIG wind turbine

only one wind turbine is applied to represent the equivalent wind farm. Fig. 3 shows the single line diagram of the sample power system that is considered in this paper [11].

III. MODELING AND CONTROL

A. DFIG

The basic configuration of a DFIG based on wind turbine is represented in Fig. 4. The power electronic converter includes two four-quadrant insulated-gated bipolar transistor (IGBT) pulse width modulation (PWM) converters connected back-to-

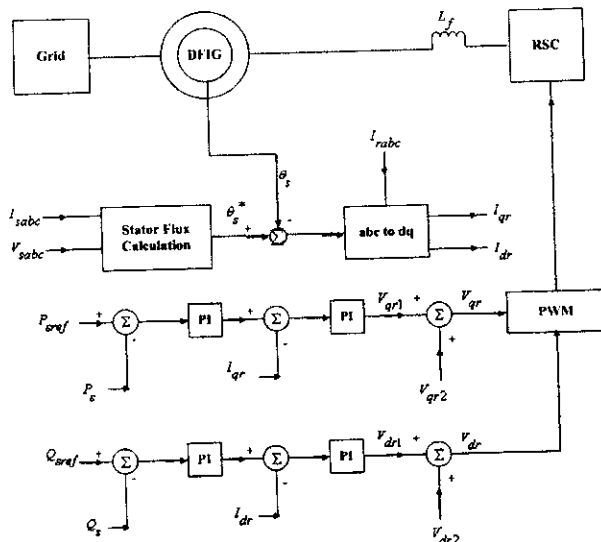

Fig. 5. Overall vector control of the RSC

back means of a dc-link capacitor. Control of DFIG is achieved via control of the VFC that consists of RSC and GSC control [7], [11], [12]. The objective of RSC control is regulation of the stator active and reactive powers that are represented as P_s, Q_s in Fig. 4 respectively. Fig. 5 represents the overall vector control scheme of the RSC [7], [11], [12]. On the other hand, the purpose of the GSC control is to keep dc-link voltage constant with respect to the magnitude and direction of the rotor power flow. Fig. 6 represents the overall control scheme of the GSC [7], [11], [12].

B. SEF-DFIG

Unlike the conventional vector control of DFIG, control of dc-link voltage of the rotor side inverter in SEF-DFIG requires further considerations [5]. Since power in the rotor side inverter flows via the rotor windings, the dc link voltage level of the inverter depends only on the rotor power P_r , which is supplied from the rotor windings through the rotor side inverter. In case of $P_r > 0$, the energy stored in the dc link capacitor is supplied to the rotor and the voltage level decreases and in case of $P_r < 0$, the energy from the rotor is transferred to the dc link capacitor and the voltage level increases. It means that the voltage level of the dc link can be regulated by controlling the rotor flow.

Stator flux reference frame is used for the vector control of SEF-DFIG. In SEF-DFIG it can be written:

$$P_r = -P_{dc} = -V_{dc}I_{dc} = -V_{dc}C_{dc} \frac{dV_{dc}}{dt} \quad (1)$$

Where P_{dc} is power and I_{dc} is current into the dc link capacitor and C_{dc} is the capacitance of the dc link. As equation

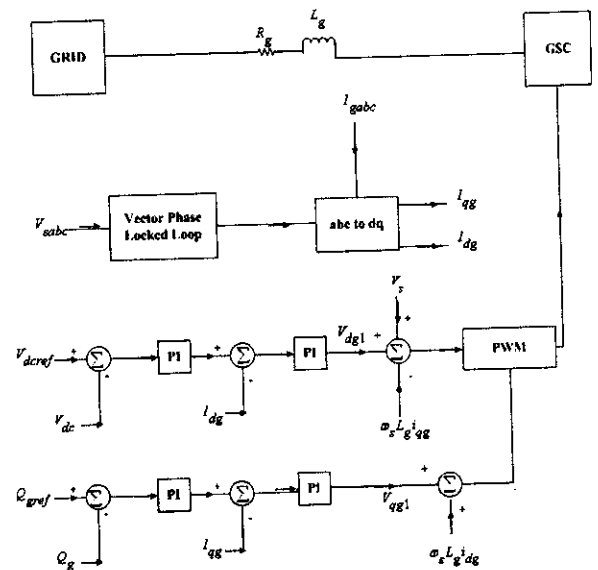

Fig. 6. Overall control scheme of the GSC

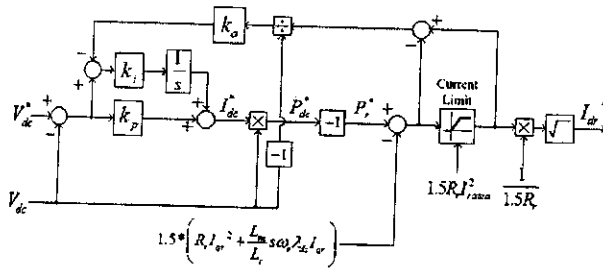

Fig. 7. Control of dc link voltage in SEF-DFIG

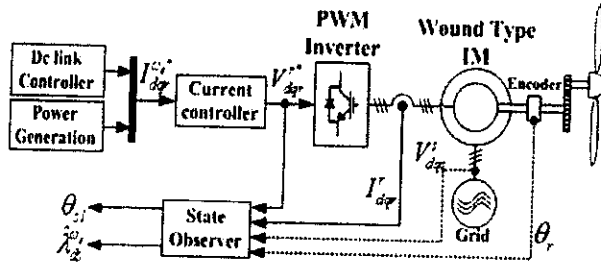

Fig. 8. Overall vector Control of SEF-DFIG

(1), the controller can be designed using a proportional integral (PI) controller to regulate the dc link voltage.

$$(V_{dc}^* - V_{dc})(K_p + \frac{K_i}{s}) = I_{dc}^* = sC_{dc}V_{dc} \quad (2)$$

From the reference of the dc link current, the reference of the d-axis rotor current is obtained [5]. It means that dc link voltage can be controlled by I_{dr}^* , as shown in Fig. 7.

In SEF-DFIG, the generated power is determined by I_{qr} . The control priority is given to the dc voltage control output I_{dr}^* because the stability of the dc link voltage is the most important. Fig. 8, shows the vector control of SEF-DFIG.

C. Wind Turbine

The mechanical power that is extracted from the wind characteristic of a wind turbine depends on many important factors. A basic equation of mechanical power is often used for torque and power characteristics description of wind turbine that is:

$$P_m = \frac{1}{2} \rho A C_p(\lambda, \beta) V_\omega^3 \quad (3)$$

Where ρ is density of air in kilograms per meter, A is the cross section of the turbine in square meter, C_p is the power coefficient which is a function of rotor tip speed (λ) and the blade pitch angle (β) that given by the wind turbine manufacture. V_ω is wind speed in meter per second.

D. STATCOM

A STATCOM is shunt-connected FACTSs device that is capable generating and/or absorbing reactive power. Usually, the STATCOM is applied to voltage support aims. Recently a large number of wind turbines installed are of the variable speed type fitted with DFIGs and SEF-DFIGs. Under normal operating conditions the DFIGs operate at close to unity power factor and may supply some reactive power during system disturbances such as a three phase fault close to wind farm in order to meet the LVRT grid code requirements. The STATCOM can be used efficiently in wind farms to provide transient voltage support to prevent system collapse.

In this paper, the STATCOM is modeled means of a gate turn-off thyristor (GTO) PWM converter with a dc-link Capacitor. The control scheme of the STATCOM is represented in Fig. 9. [13], [14].

E. FCL

The duty of fault current limiters is to limit fault currents by rapid insertion of a series inductance in the fault path. In this paper, an FCL is applied to limit the rotor current of SEF-DFIG during grid faults. This FCL is placed in series with the rotor. The type of FCL that is applied in this paper is static current limiter (SCL). The SCL is consist of an Anti-parallel Gate turn-off thyristor (GTO) switch, a current limiting inductor and a zinc oxide (ZNO) arrester. Fig. 10 shows the scheme of FCL that have used in the rotor circuit of SEF-DFIG. Under normal operating conditions, the GTOs are gated for full conduction. Once a fault occurs, the GTOs are turned off as soon as the fault is detected. A GTO can respond within a few microseconds.

When the GTOs are turned off, the fault current is diverted

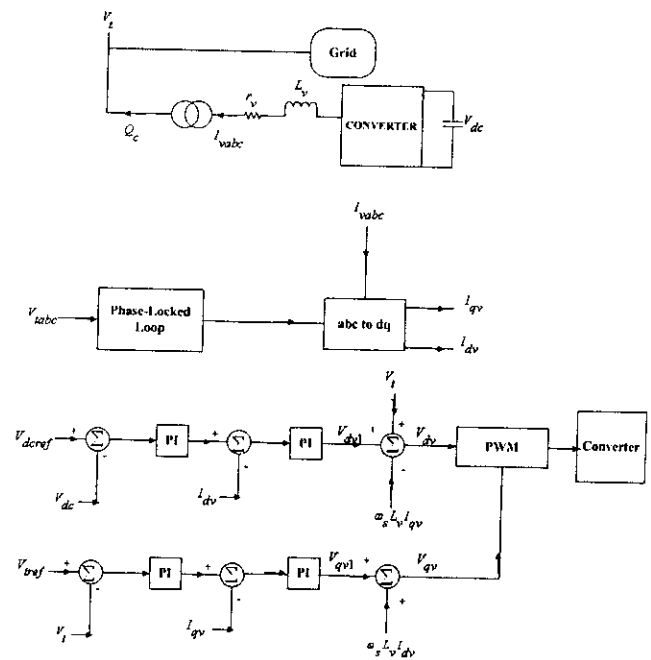

Fig. 9. Control scheme of the STATCOM

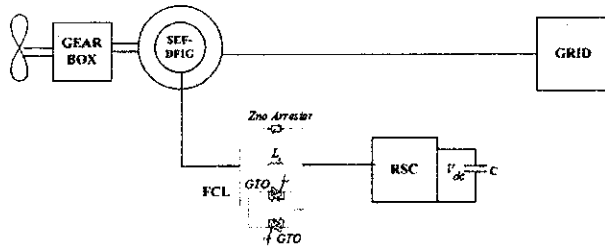

Fig. 10. Scheme of SCL that is used in SEF-DFIG

to the snubber capacitor that limits the rate of rise in voltage across the GTOs. The voltage across the anti-parallel GTO switch rises until it reaches the clamping level established by ZNO arrester. When the clamping level of the voltage is reached, the current across the inductor will rise linearly. This linear rise will continue till it becomes equal to the instantaneous level of current flowing in the line, thus the current will be limited [11].

IV. SIMULATION

Simulation has been executed with PSCAD/EMTDC software. In this paper, the simulation has been done proceed on 5 stages that have been presented with complete details in each subsection as above.

A. DFIG Simulation During Grid Fault with Crow Bar Technique

In this stage, limiting of the rotor current with blocking technique of RSC and using crow-bar in the rotor circuit for RSC protection short circuit condition has been applied for simulation. In this case, a STATCOM is used for reactive

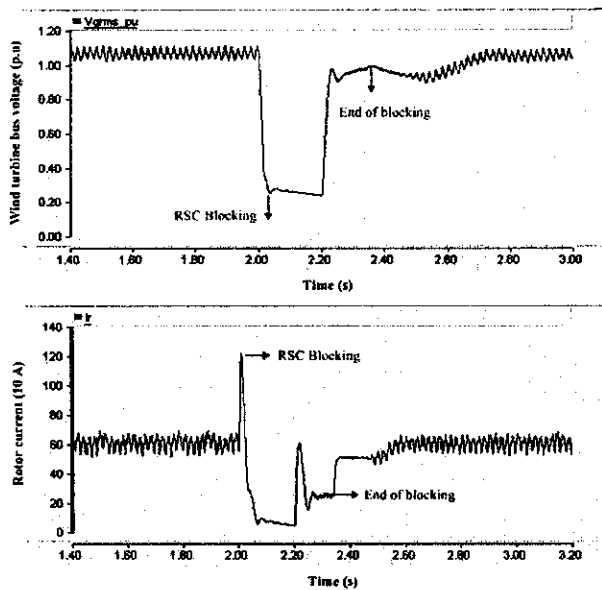

Fig. 11. Rotor circuit current and WTS bus voltage during grid fault with RSC blocking technique

power compensation and uninterrupted operating of wind turbine. A 3 phase short circuit has been applied to the power system bus at $t = 2$ s. In $t = 2.03$ the RSC is blocked and the crow-bar short circuited the rotor circuit. The fault is cleared at $t = 2.2$ s and in $t = 2.35$ s the RSC returns to normal operation. Fig.11 represents the current of the rotor circuit and voltage of generator bus for this stage of simulation.

B. DFIG Simulation During Grid Fault with FCL Technique

In this stage, A three phase short circuit has been imposed to the power system bus at $t = 2$ s. After detecting voltage dip, GTOs of the FCL turned off quickly and a large inductance placed in the rotor circuit for limiting the current. In $t = 2.2$ s the fault is cleared and then after reaching the voltage to the specified level the GTOs of the FCL turned on and the inductance has been forced to get throw out of the rotor circuit. At this stage, a STATCOM has been adopted for reactive power compensation. Fig. 12 shows the rotor circuit current and voltage for WTS bus.

C. SEF-DFIG Simulation During Normal Condition

In this stage, the SEF-DFIG wind turbine system shown in Fig.3, applying in grid normal condition. Fig. 13 represents the rotor current and WTS voltage during mentioned simulation respectively.

D. SEF-DFIG Simulation During Grid Fault with Crow-Bar Technique

For the conventional DFIG, they have applied a crow-bar circuit method for protection rotor circuit during grid fault. This LVRT strategy for DFIG can be applied to the SEF-DFIG in the exactly same manner as that of the conventional DFIG because both have the rotor side inverter in common and the role of the grid side converter much decrease in the case of

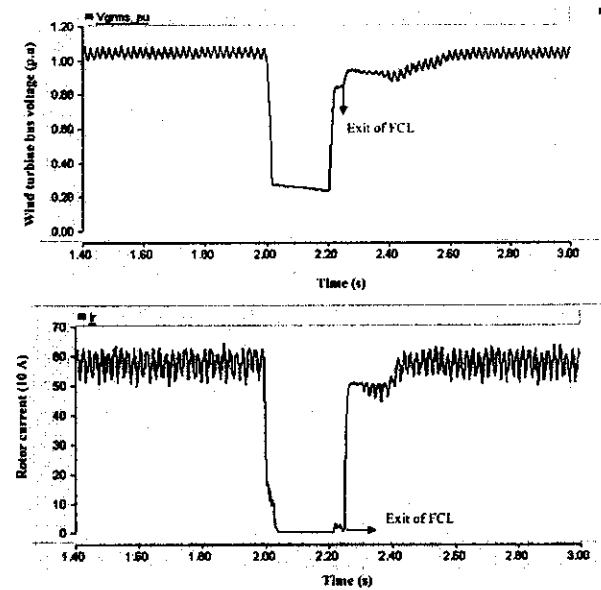

Fig. 12. Rotor circuit current and WTS bus voltage during grid fault with using FCL

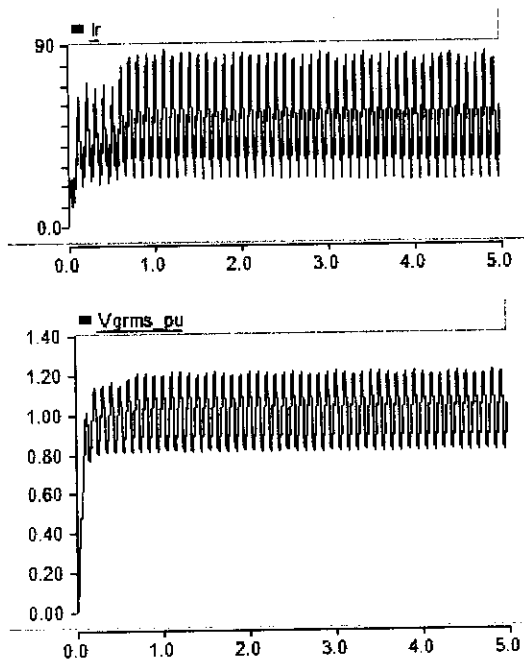

Fig. 13. SEF-DFIG rotor current WTS bus voltage during grid normal condition

voltage sag [5].

A three phase short circuit has been imposed to the transmission line at $t = 2$ s. after 150 ms the short circuit has been cleared. 2 ms after applying the fault ($t = 2.002$ s), the RSC is blocked to protect it from over current in the rotor circuit. Fig. 14 represents the rotor current and WTS voltage during this stage.

E. SEF-DFIG Simulation During Grid Fault with FCL Technique

In this stage, shows the effects of FCL on operation of SEF-DFIG in wind turbine systems during grid fault. a three phase short circuit has been imposed to the power system bus at $t = 2$ s. After detecting voltage dip, GTOs of the FCL turned off quickly and a large inductance is placed in the rotor circuit for limiting the current. In $t = 2.2$ s the fault is cleared and then after reaching the voltage to the specified level the GTOs of the FCL turned on and the inductance out of the rotor circuit. Fig. 15 shows the rotor circuit current and voltage for WTS bus.

V. CONCLUSION

This paper, has investigate effects of FCL on operation of SEF-DFIG in wind turbine systems during grid fault. In the SEF-DFIG configuration, the stator is directly connected to the grid when the rotor is connected to the PWM inverter, which is not fed by any external source. Since the rotor side converter is isolated from the grid. The FCL is placed in series with rotor circuit and protects the RSC from the over currents that has been induced during fault condition on the power system. Also the paper has applied a STATCOM that is parallel with the

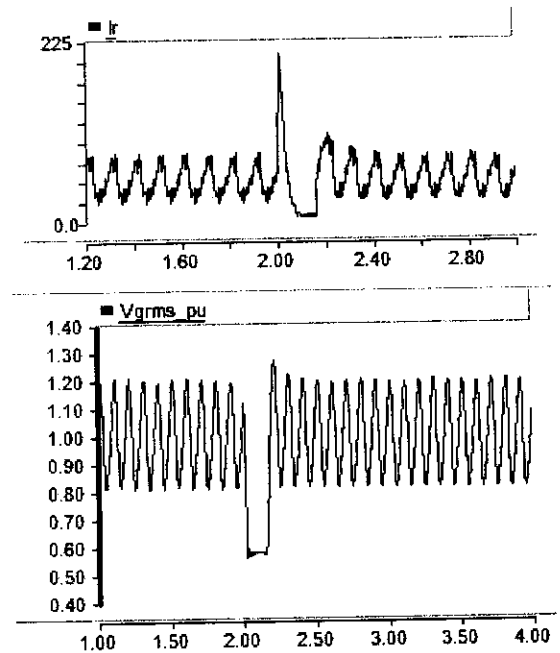

Fig. 14. SEF-DFIG rotor current and WTS bus voltage during grid fault with crow-bar technique

WTS bus for supplying required reactive power in fault condition and steady states operation.

Simulation results show operation of DFIG and SEF-DFIG during grid fault as same. Also during normal condition, since in SEF-DFIG dc link voltage level can be lower than

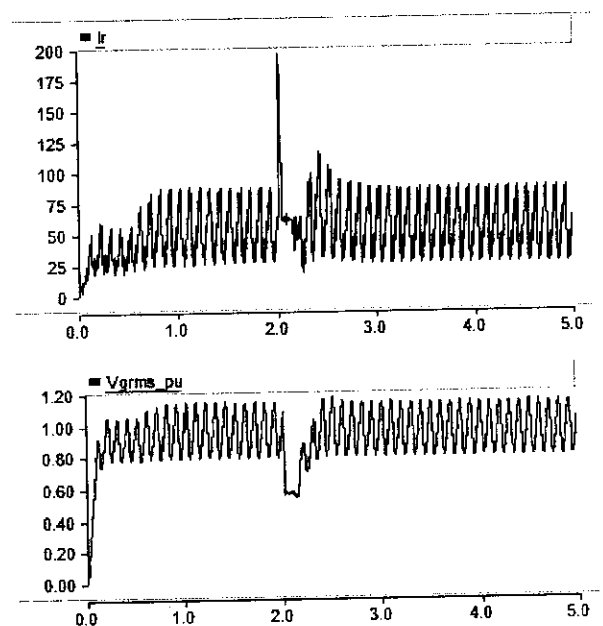

Fig. 15. SEF-DFIG rotor current and WTS bus voltage during grid fault with FCL technique

conventional DFIG, reduces switching loss and efficiency of SEF-DFIG is higher. Eliminating the grid side converter and filters, can reduce the systems cost and complexity.

REFERENCES

- [1] Global Wind Energy Council (GWEC). Available: <http://www.gwec.net>.
- [2] B. Wu, Y. Lang, N. Zargari, S. Kouro, "Power conversion and control of wind energy systems", Wiley- IEEE press, 2011.
- [3] R. Datta, V. T. Ranganathan, "Variable Speed Wind Power Generation Using doubly fed wound rotor induction machine- a comparison with alternative schemes," IEEE Trans. Energy Convers., vol. 17, no. 3, pp 414-421, sep 2002.
- [4] M. Liserre, R. Cardenas, M. Molinas, J. Rodriguez, "Overview of multi - MW wind turbines and wind parks," IEEE Trans. Ind. Electr., vol. 58, no. 4, pp.1081-1095, 2011.
- [5] Y. Han, S. Kim, J. Ha, W. Lee, "A Doubly Fed Induction Generator Controlled in Single Sided Grid connection for Wind Turbines," IEEE Trans. energy. convers., vol. 28, no. 2, June. 2013.
- [6] V. Akhmatov, "Analysis of dynamic behavior of electric power systems With large amount of wind power." Ph.D. dissertation, Tech. unv. Kgs. Lyngby, Denmark, Apr.2003.
- [7] W. Qiao, G. K. Venayagamoorthy, R. G. Harley, "Real Time implementation of a STATCOM on a Wind Turbine Equipped With Doubly Fed Induction Generators," IEEE Trans. Energy Convers., vol. 45, no. 1, Jan. 2009.
- [8] J. Morren and S. W. H. de Haan, "Ridethrough of wind turbines w doubly fed induction generator during a voltage dip," IEEE Tra Energy Convers., vol. 20, no. 2, pp. 435-441, Jun. 2005.
- [9] A. Mullane, G. Lightbody, and R. Yacamini, "Wind turbine fault ride through enhancement," IEEE Trans. Power Syst., vol. 20, no. 4, pp. 1929-1937, Nov. 2005.
- [10] R. G. de Almeida, J. A. P. Lopes, and J. A. L. Barreiros, "Improving power system dynamic behavior through doubly fed induction machine controlled by static converter using fuzzy control," IEEE Trans. Power Syst., vol. 19, no. 4, pp. 1942-1950, Nov. 2004.
- [11] M. Fazli and N. Talebi, "A New Method for Uninterrupted Operation of Wind Turbine Equipped with DFIGs during Grid Faults Using FCL," 5th International Conference on environment and Electrical Engineering (EEEIC), Prague, Czech Republic, May 2010.
- [12] R. Pena, J. C. Clare, and G. M. Asher, "Doubly fed induction generator using back-to-back PWM converter and its application to variable speed wind energy generation," Proc. Inst. Elect. Eng.-Elect. Power Appl., vol. 143, no. 3, pp. 231-241, May. 1996.
- [13] M. Fazli, A. R. Shafiqi, A. Fazli, H. A. Shayanfar, "Effects of STATCOM on wind turbines equipped with DFIGs during grid faults" World non-grid-connected wind power and energy conference (WNWEC), Nanjing, China, Nov 2010.
- [14] C. Schauder and H. Mehta, "Vector analysis and control of advanced static VAR compensator," Proc. Inst. Elect. Eng.-Gener. Transm. Distrib., vol. 140, no. 4, pp. 299-306, Jul. 1993.