

Joint Constrained LMS Algorithm and Base Station Assignment for DS-CDMA Receiver in Multipath Fading Channels

Mohammad Dosarianian Moghaddam
Department of Electrical Engineering
Qazvin Islamic Azad University
Qazvin, Iran
email: m_dmoghadam@qiau.ac.ir

Hamidreza Bakhshi and Gholamreza Dadashzadeh
Department of Electrical Engineering
Shahed University
Tehran, Iran
emails: bakhshi@shahed.ac.ir, gdadash@itrc.ac.ir

Abstract— In this paper, we propose base station assignment method based on minimizing the transmitter power (BSA-MTP) technique in a direct sequence-code division multiple access (DS-CDMA) receiver in the presence of frequency-selective Rayleigh fading. This receiver consists of three stages. In the first stage, with constrained least mean squared (CLMS) algorithm, the desired users' signal in an arbitrary path is passed and the inter-path interference (IPI) is reduced in other paths in each RAKE finger. Also in this stage, the multiple access interference (MAI) from other users is reduced. Thus, the matched filter (MF) can use for the MAI and IPI reduction in each RAKE finger in the second stage. Also in the third stage, the output signals from the matched filters are combined according to the conventional maximal ratio combining (MRC) principle and then are fed into the decision circuit of the desired user. The simulation results indicate that the BSA-MTP technique can significantly improve the network bit error rate (BER) in comparison with the other algorithms.

Keywords- Adaptive beamforming; base station assignment; DS-CDMA; maximal ratio combining; perfect power control.

I. INTRODUCTION

Systems utilizing code-division multiple access (CDMA) are currently being deployed around the country and around the world in response to the ever increasing demand for cellular/personal communications services. Extensive research has been published on the performance analysis of CDMA systems. Fading is among the major factors affecting the performance of such systems. Fading is generally characterized according to its effect over a geographical area. Large-scale fading consists of path loss and shadowing, the latter term referring to fluctuations in the received signal mean power. Large-scale fading is affected by prominent terrain contours between the transmitter and receiver. Small-scale fading is the common reference to the rapid changes in signal amplitude and phase over a small spatial separation. In this work, the combined effect of large- and small-scale fading are considered. The small-scale fading is assumed to be governed by the Rayleigh distribution (Rayleigh fading) [1]. Besides fading,

CDMA systems are susceptible to the near-far problem. It is well known that in order to fully exploit the potential advantage of CDMA systems, power control is required to counteract the effects of the near-far problem. The CDMA system capacity is maximized if each mobile transmitter power level is controlled so that its signal arrives at the base station (BS) with the minimum required signal-to-interference-plus-noise ratio (SINR) [1]-[6]. In this work, we assume perfect power control (PPC) in order to compensate the near-far problem. Accordingly, the received power in base station of all users is fixed.

Also diversity is one effective technique for enhancing the SINR for wireless networks. Diversity exploits the random nature of radio propagation by finding independent (or, at least, highly uncorrelated) signal paths for communication. If one radio path undergoes a deep fade, another independent path may have a strong signal. By having more than one path to select from, the SINR at the receiver can be improved. The diversity scheme can be divided into three methods: 1) the space diversity; 2) the time diversity; 3) the frequency diversity. In these schemes, the same information is first received (or transmitted) at different locations (or time slots/frequency bands). After that, these signals are combined to increase the received SINR. The antenna array is an example of the space diversity, which uses a beamformer to increase the SINR for a particular direction [7]-[9]. In this work, we use constrained least mean squared (CLMS) algorithm for the space diversity.

To improve the performance of cellular systems, base station assignment technique can be used. In the joint power control and base station assignment (BSA), a number of base stations are potential receivers of a mobile transmitter. Here, the objective is to determine the assignment of users to base stations which minimizes the allocated mobile powers [10]-[13]. In simple mode and in multiple-cell systems, the user is connected to the nearest base station. This way is not optimal in cellular systems under the shadowing and multipath fading channels and can increase the system BER. In this paper, we present base station

assignment method based on minimizing the transmitter power (BSA-MTP) for decreasing the BER in all cells.

The goal of this paper is to extend the works in [14] and [15] by considering multiple-cell system and base station assignment technique. In these works, a RAKE receiver in single-cell system with conjugate gradient (CG) adaptive beamforming was proposed in the presence of frequency-selective Rayleigh fading channel, and perfect power control (PPC) was considered.

In this work, the performance analysis of direct-sequence (DS)-CDMA system in frequency-selective Rayleigh fading channel has been studied. If the delay spread in a multipath channel is larger than a fraction of a symbol, the delayed components will cause inter-symbol interference (ISI). Adaptive receiver beamforming schemes have been widely used to reduce both co-channel interference (CCI) and ISI and to decrease the BER by adjusting the beam pattern such that the effective SINR at the output of the beamformer is optimally increased [16].

In this paper a RAKE receiver in DS-CDMA system is analyzed in three stages according to Fig. 1 [14]. In the first stage, this receiver uses CLMS adaptive beamforming to find optimum antenna weights assuming perfect estimation of the channel parameters (direction, delay, and power) for the desired user. The desired user resolvable paths' directions are fed to the beamformer to reduce the inter-path interference (IPI) from other directions. Also, the RAKE receiver uses conventional demodulation in the second stage and conventional maximal ratio combining (MRC) in the third stage to reduce multiple-access interference (MAI). Reducing the MAI and CCI will further decrease the BER.

The organization of the remainder of this paper is as follows. The system model is presented in Section II. The RAKE receiver structure is described in Section III. In Section IV, we propose the BSA-MTP technique. Section V describes the CG adaptive beamforming (CGBF) algorithm. Finally, simulation results and conclusions are given in Section VI and VII, respectively.

II. SYSTEM MODEL

In this paper, we focus on the uplink communication paths in a DS-CDMA cellular system. L replicas of the signal, due to both some form of diversity reception (for instance antenna diversity) and channel frequency selectivity, are assumed Rayleigh distributed and optimally combined through a RAKE receiver according to Fig.1. Also assume that there are M active base stations in the network, with K_m users connected to m th base station, where $1 \leq m \leq M$. Also assume that each base station uses an antenna array of S sensors and N weights, where $S = N$, to receive signals from all users. Also, for simplicity we assume a synchronous DS-CDMA scheme and BPSK modulation in order to simplify the analysis of proposed methods. Additionally, in this paper we assume a slow fading channel. Hence, the received signal in the base

station q and sensor s from all users can be written as [14], [17]

$$r_{q,s}(t) = \sum_k \sqrt{p'_{k,m} \Gamma_k(x,y)} \sum_{l=1}^L \alpha_{k,m,l} b_{k,m}(t - \tau_{k,m,l}) \times c_{k,m}(t - \tau_{k,m,l}) \exp(-j s k_d \sin \theta_{k,m,l}) + n(t) \quad (1)$$

where $c_{k,m}(t)$ is the pseudo noise (PN) chips of user k in cell m (user k,m) with a chip period of T_c ; $b_{k,m}(t)$ is the information bit sequence of user k,m with a bit period of $T_b = G T_c$ where G is processing gain; $\tau_{k,m,l}$ is the l th path time delay for user k,m ; $\theta_{k,m,l}$ is the direction of arrival (DoA) in the l th path for user k,m ; $\alpha_{k,m,l}$ is the complex Gaussian fading channel coefficient from the l th path of user k,m ; $k_d = 2\pi d / \lambda$ where λ is signal wavelength and d is the distance between the antenna elements that for avoid the spatial aliasing should be defined as $d = 0.5\lambda$ and $n(t)$ is an additive white Gaussian noise (AWGN) process with a two-sided power spectral density (PSD) of $N_0/2$. Also in the case of conventional BSA technique, $\Gamma_k(x,y)$ is defined as

$$\Gamma_k(x,y) = \begin{cases} 1 & ; k \in S_{BSq} \\ \frac{\min_{m \in \Theta_k} \{d_{k,m}^{L_\alpha}(x,y) 10^{\xi_{k,m}/10}\}}{d_{k,q}^{L_\alpha}(x,y) 10^{\xi_{k,q}/10}} & ; k \in S_o \end{cases} \quad (2)$$

where L_α is path-loss exponent; $d_{k,m}(x,y)$ and $d_{k,q}(x,y)$ are the distance between user k and BS m and BS q , respectively (see Fig. 2). Also the variable Θ_k defined the set of the nearest BSs to user k ; $\xi_{k,m}$ is a random variable modeling the shadowing between user k and BS m ; S_{BSq} is the set of users that connected to BS q and S_o is the set of users that not connected to BS q [3]. Also in (1):

$$p'_{k,m} = d_{k,m}^{-L_\alpha}(x,y) 10^{-\xi_{k,m}/10} \times p_{k,m} \quad (3)$$

is the received power in the BS m of user k,m in the presence of closed-loop power control where $p_{k,m}$ is the transmitted power of user k,m that in the case of the PPC, $p'_{k,m}$ is fixed for all users within cell m ($p'_{k,m} = E_b / T_b$ where E_b is the energy per bit for all users) [3], [10].

The received signal in the base station q in sensor s for user i,q is given by [10]

$$r'_{i,q,s}(t) = \sum_{l=1}^L \sqrt{p'_{i,q}} b_{i,q}(t - \tau_{i,q,l}) c_{i,q}(t - \tau_{i,q,l}) \times \alpha_{i,q,l} \exp(-j s k_d \sin \theta_{i,q,l}) + I_{i,q,s}(t) + n(t) \quad (4)$$

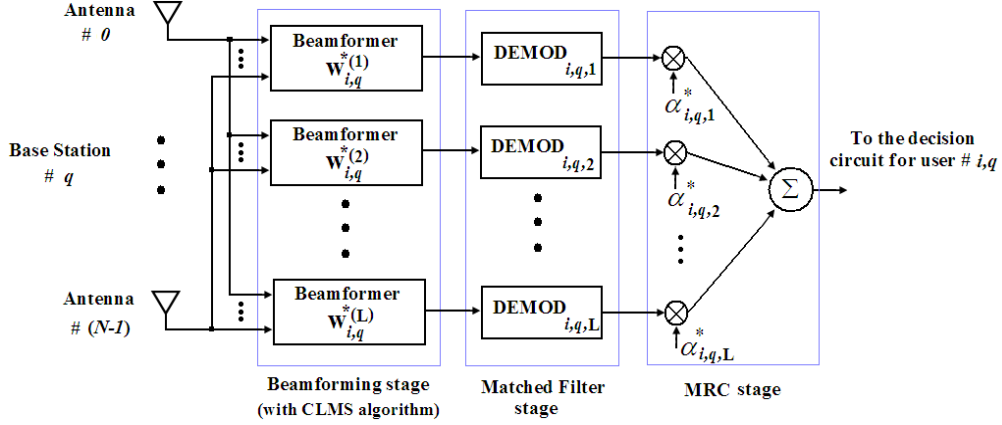

Figure 1. Block diagram of a three-stage RAKE receiver in DS-CDMA system [14].

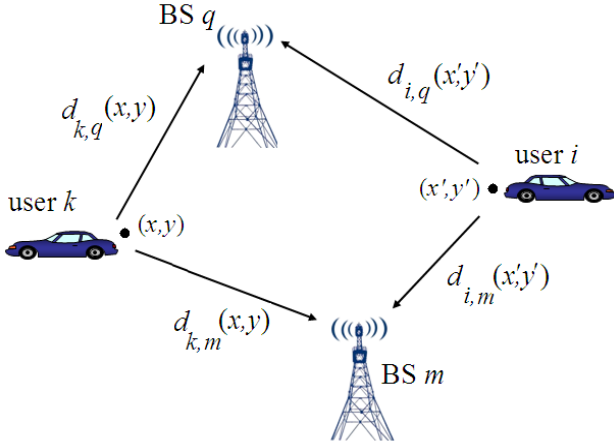

Figure 2. The distance between two pairs of mobile transmitters and base station receivers [10].

where $I_{i,q,s}(t)$ is the interference for user i,q in sensor s and can be shown to be

$$I_{i,q,s}(t) = \sum_{m=1}^M \sum_{\substack{k=1 \\ k,m \neq i,q}}^{K_m} \sum_{l=1}^L \sqrt{p'_{k,m} \Gamma_k(x,y)} b_{k,m}(t - \tau_{k,m,l}) \times c_{k,m}(t - \tau_{k,m,l}) \alpha_{k,m,l} \exp(-j s k_d \sin \theta_{k,m,l}) \quad (5)$$

where K_m is the number of users in cell m and M is the number of base stations/cells.

III. RAKE RECEIVER PERFORMANCE ANALYSIS

The RAKE receiver structure in the DS-CDMA system is shown in Fig. 1. The received signal is spatially processed by a beamforming circuit with CLMS algorithm, one for each resolvable path (L beamformers). The resultant signal is then passed on to a set of parallel matched filters (MFs), on a finger-by-finger basis. Also, the output signals from the L matched filters are combined according to the conventional MRC principle and then are fed into the decision circuit of the desired user [14].

A. Beamforming Stage

It is well known that an array of N weights has $N-1$ degree of freedom for adaptive beamforming [14], [17]. This means that with an array of N weights, one can generate $N-1$ pattern nulls and a beam maximum in desired directions. From (5), it is clear that the number of users is $K_u = \sum_{m=1}^M K_m$ and the number of interferes is $LK_u - 1$. To null all of these interferes; one would have to have LK_u weights, which is not practical. So, we focus only on the L paths of the desired user. Thus, the minimum number of the antenna array weights is L where, typically, L varies from 2 to 6 [14].

In this paper, we use the CLMS adaptive beamforming algorithm. This algorithm is a gradient based algorithm to minimize the total processor output power, based on the look direction constraint. The adaptive algorithm is designed to adapt efficiently in agreement with the environment and able to permanently preserve the desired frequency response in the look direction while minimizing the output power of the array. The combined form of the constraint is called constraint for narrowband beamforming [10], [18].

This form consider a narrowband beamformer where the narrowband signal from each element of smart antenna are multiplied by the complex weight calculated by using narrowband adaptive beamforming algorithm, and then summed to produce the output of the array. The definition of the complex weights of this beamformer in the m th iteration for user i,q in the j th path is as follows [17]-[19]:

$$\mathbf{w}_{i,q}^{(j)}(m) = [w_{i,q,0}^{(j)}(m) w_{i,q,1}^{(j)}(m) \dots w_{i,q,N-1}^{(j)}(m)]^T \quad (6)$$

Accordingly, the output of the array in the m th iteration in the j th path for user i,q is given by

$$y_{i,q}^{(j)}(m) = \mathbf{w}_{i,q}^{(j)}(m)^H \mathbf{r}'_{i,q}(m). \quad (7)$$

where $\mathbf{r}'_{i,q} = [r'_{i,q,0} \ r'_{i,q,1} \ \dots \ r'_{i,q,N-1}]^T$.

The expected output power of the array in the m th iteration is given by

$$\begin{aligned} \mathbb{E}\left(\left|y_{i,q}^{(j)}(m)\right|^2\right) &= \mathbb{E}\left(y_{i,q}^{(j)}(m)y_{i,q}^{(j)}(m)^*\right) \\ &= \mathbb{E}\left(\mathbf{w}_{i,q}^{(j)}(m)^H \mathbf{r}'_{i,q}(m) \mathbf{r}'_{i,q}(m)^H \mathbf{w}_{i,q}^{(j)}(m)\right) \\ &= \mathbf{w}_{i,q}^{(j)}(m)^H \mathbf{R}_{r'r'} \mathbf{w}_{i,q}^{(j)}(m) \end{aligned} \quad (8)$$

where $\mathbb{E}(\cdot)$ is denoted the expectation and $\mathbf{R}_{r'r'}$ is the correlation matrix of the received vector $\mathbf{r}'_{i,q}(m)$.

A real-time CLMS algorithm for determining the optimal weight vector for user i, q in the j th path is [18], [19]:

$$\begin{cases} \mathbf{w}_{i,q}^{(j)}(m+1) = \mathbf{w}_{i,q}^{(j)}(m) + \mu g(\mathbf{w}_{i,q}^{(j)}(m)) \\ \mathbf{w}_{i,q}^{(j)H} \mathbf{a}_{i,q}^{(j)}(\theta_{i,q,j}) = 1 \end{cases} \quad (9)$$

where

$$\mathbf{a}_{i,q}^{(j)}(\theta_{i,q,j}) = [1 \ e^{-jk_d \sin \theta_{i,q,j}} \ \dots \ e^{-jk_d(N-1)d \sin \theta_{i,q,j}}]^T \quad (10)$$

denotes spatial response of the array for user i, q in the j th path. Also in (9), $\mathbf{w}_{i,q}^{(j)}(m+1)$ is the new weight computed at the $(m+1)$ th iteration for user i, q in the j th path. Also, the variable scalar μ denotes a positive scalar (gradient step size) that controls the convergence characteristic of the algorithm, that is, how fast and how close the estimated weights approach the optimal weights, and $g(\mathbf{w}_{i,q}^{(j)}(m))$ denotes an unbiased estimate of the gradient of the power surface ($\mathbf{w}_{i,q}^{(j)}(m)^H \mathbf{R}_{r'r'} \mathbf{w}_{i,q}^{(j)}(m)$ which is the expected output power of the array) with respect to $\mathbf{w}_{i,q}^{(j)}(m)$ after the m th iteration. The algorithm is “constrained” because the weight vector satisfies the constraint at each iteration, that is $\mathbf{w}_{i,q}^{(j)H} \mathbf{a}_{i,q}^{(j)}(\theta_{i,q,j}) = 1$. Rewrite the CLMS algorithm as follows [18].

$$\mathbf{w}_{i,q}^{(j)}(m+1) = \beta_{i,q}^{(j)} \left(\mathbf{w}_{i,q}^{(j)}(m) + \mu g(\mathbf{w}_{i,q}^{(j)}(m)) \right) + \frac{\mathbf{a}_{i,q}^{(j)}(\theta_{i,q,j})}{N} \quad (11)$$

where

$$\beta_{i,q}^{(j)} = \mathbf{I} - \frac{\mathbf{a}_{i,q}^{(j)}(\theta_{i,q,j}) \mathbf{a}_{i,q}^{(j)H}(\theta_{i,q,j})}{N}. \quad (12)$$

The gradient of $\mathbf{w}_{i,q}^{(j)}(m)^H \mathbf{R}_{r'r'} \mathbf{w}_{i,q}^{(j)}(m)$ with respect to $\mathbf{w}_{i,q}^{(j)}(m)$ is given by [18]

$$\begin{aligned} g(\mathbf{w}_{i,q}^{(j)}(m)) &\stackrel{\Delta}{=} -\frac{\partial}{\partial \mathbf{w}_{i,q}^{(j)*}} \left(\mathbf{w}_{i,q}^{(j)}(m)^H \mathbf{R}_{r'r'} \mathbf{w}_{i,q}^{(j)}(m) \right) \\ &= -2\mathbf{R}_{r'r'} \mathbf{w}_{i,q}^{(j)}(m) \end{aligned} \quad (13)$$

and its computation using this expression requires knowledge of $\mathbf{R}_{r'r'}$, which normally is not available in practice. For a standard LMS algorithm, an estimate of the gradient at each iteration is made by replacing $\mathbf{R}_{r'r'}$ by its noise sample $\mathbf{r}'_{i,q}(m+1)\mathbf{r}'_{i,q}(m+1)^H$ available at time instant $(m+1)$, leading to

$$g(\mathbf{w}_{i,q}^{(j)}(m)) = -2\mathbf{r}'_{i,q}(m+1)y_{i,q}^{(j)*}(m). \quad (14)$$

The CLMS is a fast convergence algorithm. However, it is drastically sensitive to the mismatch in the direction of arrival. Meanwhile, the weights estimated by the standard algorithm are sensitive to the signal power, requiring a lower step size in the presence of a strong signal for the algorithm to converge, which in turn regarding the decrease of mis-adjustment error, the convergence time is increased [18], [20].

It should be mentioned that for the array antenna weight vector elements in the CLMS algorithm and for big μ , will converge after a few iteration (is approximately equal to the number of beamformer weights, i.e., $m = N$) [20].

Accordingly, the output signal from the j th beamformer ($j = 1, \dots, L$) can be written as [14]

$$\begin{aligned} y_{i,q}^{(j)}(t) &= \sqrt{p'_{i,q}} b_{i,q}(t - \tau_{i,q,j}) c_{i,q}(t - \tau_{i,q,j}) \alpha_{i,q,j} \\ &\quad + \tilde{I}_{i,q}^{(j)}(t) + I_{i,q}^{(j)}(t) + n^{(j)}(t) \end{aligned} \quad (15)$$

where $n^{(j)}(t)$ is a zero mean Gaussian noise of variance σ_n^2 and $\tilde{I}_{i,q}^{(j)}(t)$, the CCI, is defined as

$$\begin{aligned} \tilde{I}_{i,q}^{(j)}(t) &= \sum_{l=1, l \neq j}^L \sqrt{p'_{i,q}} g_{i,q}^{(j)}(\theta_{i,q,l}) \alpha_{i,q,l} b_{i,q}(t - \tau_{i,q,l}) \\ &\quad \times c_{i,q}(t - \tau_{i,q,l}) \end{aligned} \quad (16)$$

and $I_{i,q}^{(j)}(t)$, the MAI, is defined as [14]

$$\begin{aligned} I_{i,q}^{(j)}(t) &= \sum_{m=1}^M \sum_{\substack{k=1 \\ k, m \neq i, q}}^{K_m} \sum_{l=1}^L \sqrt{p'_{k,m}} \Gamma_k(x, y) g_{i,q}^{(j)}(\theta_{k,m,l}) \\ &\quad \times \alpha_{k,m,l} b_{k,m}(t - \tau_{k,m,l}) c_{k,m}(t - \tau_{k,m,l}) \end{aligned} \quad (17)$$

where $g_{i,q}^{(j)}(\theta)$ is the magnitude response of the j th beamformer for user i, q toward the direction of arrival θ .

B. Matched Filter Stage

Using beamforming will only cancel out the inter-path interference for the desired user and will reduce the MAI from the users whose signals arrive at different angles from the desired user signal (out-beam interference). Now, in the second stage of the RAKE receiver, the output signal from the j th beamformer is directly passes on to a filter matched to the desired user's signature sequence. The j th matched filter output corresponding to the n th bit is [14]:

$$z_{i,q}^{(j)}(n) = \sqrt{p'_{i,q}} b_{i,q}(n) \alpha_{i,q,j} + \tilde{I}_{i,q}^{(j)}(n) + I_{i,q}^{(j)}(n) + n'^{(j)}(n) \quad (18)$$

where

$$\tilde{I}_{i,q}^{(j)}(n) = \frac{1}{T_b} \int_{(n-1)T_b + \tau_{i,q,j}}^{nT_b + \tau_{i,q,j}} \tilde{I}_{i,q}^{(j)}(t) c_{i,q}(t - \tau_{i,q,j}) dt \quad (19)$$

$$I_{i,q}^{(j)}(n) = \frac{1}{T_b} \int_{(n-1)T_b + \tau_{i,q,j}}^{nT_b + \tau_{i,q,j}} I_{i,q}^{(j)}(t) c_{i,q}(t - \tau_{i,q,j}) dt \quad (20)$$

and

$$n'^{(j)}(n) = \frac{1}{T_b} \int_{(n-1)T_b + \tau_{i,q,j}}^{nT_b + \tau_{i,q,j}} n^{(j)}(t) c_{i,q}(t - \tau_{i,q,j}) dt. \quad (21)$$

If we assume that the paths' delays from all users are less than the symbol duration ($\tau_{k,m,l} < T_b$) for all users' signals on all paths, the n th bit MAI at the output of the j th matched filter can be expressed as [14]

$$\tilde{I}_{i,q}^{(j)}(n) = \sum_{\substack{l=1 \\ l \neq j}}^L \sqrt{p'_{i,q}} g_{i,q}^{(j)}(\theta_{i,q,l}) \alpha_{i,q,l} b_{i,q}(n) R_{i,i}(\tau_{i,q,j} - \tau_{i,q,l}) \quad (22)$$

and

$$I_{i,q}^{(j)}(n) = \sum_{m=1}^M \sum_{\substack{k=1 \\ k, m \neq i, q}}^{K_m} \sum_{l=1}^L \sqrt{p'_{k,m}} \Gamma_k(x, y) g_{i,q}^{(j)}(\theta_{k,m,l}) \times \alpha_{k,m,l} b_{k,m}(n) R_{i,k}(\tau_{i,q,j} - \tau_{k,m,l}) \quad (23)$$

where the autocorrelation function $R_{i,k}(\tau)$ is [14], [21]:

$$R_{i,k}(\tau) = \frac{1}{T_b} \int_{T_b} c_{i,q}(t) c_{k,m}(t + \tau) dt. \quad (24)$$

If all users' delays are multiples of the chip period, then

$$\text{SINR}_{i,q}^{(j)}(\alpha) = \frac{|\alpha_{i,q,j}|^2}{\bar{\alpha}_{i,q,j}^2 \sum_{l=1}^L |g_{i,q}^{(j)}(\theta_{i,q,l})|^2 R_{i,i}^2(\tau_{i,q,j} - \tau_{i,q,l}) + \sum_{m=1}^M \sum_{\substack{k=1 \\ k, m \neq i, q}}^{K_m} \bar{\Gamma}_k(x, y) \bar{\alpha}_{k,m,j}^2 \sum_{l=1}^L |g_{i,q}^{(j)}(\theta_{k,m,l})|^2 R_{i,k}^2(\tau_{i,q,j} - \tau_{k,m,l}) + \frac{0.5}{E_b/N_0}} \quad (30)$$

$$R_{i,k}(\tau) = \frac{1}{G} \sum_{l_1=0}^{G-1} \sum_{l_2=0}^{G-1} c_{i,q}(l_1) c_{k,m}(l_2) R_c(\tau - (l_1 - l_2)T_c) \quad (25)$$

where the autocorrelation function $R_c(\tau)$ is:

$$R_c(\tau) = \frac{1}{T_b} \int_{T_b} c(t) c(t + \tau) dt. \quad (26)$$

In the case of a maximal-length sequence (m-sequence) and for $0 \leq \tau \leq T_b$, we have [21]:

$$R_c(\tau) = \begin{cases} 1 - \frac{|\tau|}{T_c} (1 + 1/G) & ; |\tau| \leq T_c \\ -1/G & ; |\tau| \geq T_c. \end{cases} \quad (27)$$

C. Maximal Ratio Combining Stage

Diversity combining has been considered as an efficient way to combat multipath fading because the combined SINR is increased compared with the SINR of each diversity branch. The optimum combiner is the MRC whose SINR is the sum of the SINR's of each individual diversity branch [21].

After the finger-matched filter, the fingers' signals are combined according to the MRC principle in the third stage of the RAKE receiver. In this paper, we use the conventional MRC that the signal of user i, q in the j th path is combined using multiplying by the complex conjugate of $\alpha_{i,q,j}$.

The SINR in output of the RAKE receiver for user i, q is [14]:

$$\text{SINR}_{i,q}(\alpha) = \sum_{j=1}^L \text{SINR}_{i,q}^{(j)}(\alpha) \quad (28)$$

where

$$\text{SINR}_{i,q}^{(j)}(\alpha) = \frac{p'_{i,q} |\alpha_{i,q,j}|^2}{E(\tilde{I}_{i,q}^{(j)})^2 + E(I_{i,q}^{(j)})^2 + E(n'^{(j)})^2} \quad (29)$$

is the SINR in output of the RAKE receiver in path j for user i, q .

Also, we can be rewritten the SINR in (29) by (30), that shown at the bottom of the page [14], where $\bar{\Gamma}_k(x, y) = E(\Gamma_k(x, y))$ and $\bar{\alpha}_{k,m,j}^2 = E(|\alpha_{k,m,j}|^2)$.

In order to perform the BER, we assume Gaussian

approximation for the probability density function of interference plus noise. The conditional BER for a BPSK modulation is [14], [21]:

$$\text{BER}_{i,q}(\alpha) = Q\left(\sqrt{2 \times \text{SINR}_{i,q}(\alpha)}\right) \quad (31)$$

where

$$Q(x) = \frac{1}{\sqrt{2\pi}} \int_x^{\infty} \exp(-u^2/2) du. \quad (32)$$

IV. BSA-MTP TECHNIQUE

The system capacity might be improved, if the users are allowed to switch to alternative base stations, especially when there are congested areas in the network. Obviously, when uplink performance is of concern, the switching should happen based on the total interferences seen by the base stations [13].

So far, we have considered the power control problem for a number of transmitter-receiver pairs with fixed assignments, which can be used in uplink or downlink in mobile communication systems. In an uplink scenario where base stations are equipped with antenna arrays, the problem of joint power control and beamforming, as well as base station assignment, naturally arises [10].

In this paper, we modify the BSA-MTP technique to support base station assignment as well. The modified technique can be summarized as follows.

- 1) Initially by the conventional BSA technique, each mobile connects to its base station, according to (2).
- 2) Estimate the weight vector for all users with the CLMS algorithm using (11).
- 3) Finally, $K_r = \lfloor K_u / M \rfloor$ users that their transmitted power is higher than the other users to be transferred to other base stations according to the following equation, where the function $\lfloor x \rfloor$ returns the integer portion of a number x .

$$\Gamma_k(x, y) = \begin{cases} 1 & ; k \in S_{\text{BS}q} \\ \frac{\min_{m \in \Theta_k, m \neq q} \left\{ d_{k,m}^{L_\alpha}(x, y) 10^{\xi_{k,m}/10} \right\}}{d_{k,q}^{L_\alpha}(x, y) 10^{\xi_{k,q}/10}} & ; k \in S_{\overline{\text{BS}q}} \\ \frac{\min_{m \in \Theta_k} \left\{ d_{k,m}^{L_\alpha}(x, y) 10^{\xi_{k,m}/10} \right\}}{d_{k,q}^{L_\alpha}(x, y) 10^{\xi_{k,q}/10}} & ; k \in S_o \end{cases} \quad (33)$$

where $S_{\overline{\text{BS}q}}$ is the set of users that are in cell q but not connected to BS q [3].

V. THE CGBF ALGORITHM

In this method, unlike other adaptive algorithms, the number of weights is less than the number of sensors such that $S = 2N - 1$. The CGBF algorithm is used of orthogonal principle to find optimum antenna weights. On this basis, a set of vectors \mathbf{w}_i is to select such that they are \mathbf{A} -orthogonal, i.e., $\langle \mathbf{A}\mathbf{w}_i, \mathbf{A}\mathbf{w}_j \rangle = 0$ for $i \neq j$ [9]. Hence, by the CGBE algorithm, desired users' signal in an arbitrary path is passed and the IPI is canceled in other paths in each RAKE finger, i.e., $\tilde{T}_{i,q}^{(j)}(t) = 0$, while the IPI is not removed in the CLMS algorithm [16].

From the above discussion, we can conclude that the BER in the CGBF algorithm is less than the CLMS algorithm. In the simulation study we will evaluate the average BER in a DS-CDMA receiver with the CGBF and CLMS algorithms.

VI. SIMULATION RESULTS

We consider $M = 4$ base stations for a four-cell CDMA system on a 2×2 grid. We assume a uniform linear array of S omni-directional antennas in each base station with antenna spacing $d = \lambda/2$. Also, we assume the input data rate $T_b = 9.6$ Kbps; the number of antenna weights $N = 3$; the number of antenna sensors $S = 3$; frequency-selective fading channel with $L = 2$ resolvable propagation paths; variance of the complex Gaussian fading channel coefficient $\sigma_\alpha^2 = 4$ dB; variance of the log-normal shadow fading $\sigma_\xi^2 = 8$ dB; path-loss component $L_\alpha = 4$; resolution $R = 1$; processing gain $G = 64$ (for m-sequence code) initial value for weight vectors in CLMS and CGBF algorithms $\mathbf{w}(0) = \mathbf{0}$. The SINR target value is the same for all users and is set to $\gamma^* = 5(7\text{dB})$. It also is assumed that the distribution of users in all cells is uniform.

Fig. 3 shows the average BER versus the signal-to-noise ratio (SNR) for different receivers (one, two, and three-stage receivers) in the case of $K_u = 32$ active users and the PPC case. It should be mentioned that in this simulation, $K_r = 8$ users can to be transferred to other base stations with the BSA-MTP technique. It is clear that, in MF only receiver (one-stage receiver) and in the case of the conventional BSA technique, we still have the error floor at high SNR. Using CLMS and MRC receiver (two-stage RAKE receiver) or CLMS, MF, and MRC receiver (the three-stage RAKE receiver as Fig. 1) has a better performance than using MF only. Also observe that using the BAS-MTP technique in the case of three-stage RAKE receiver, the average BER is lower than the conventional BSA technique. For example, at a SNR of 20dB, the average BER is 0.0096 for the three-stage RAKE receiver with the conventional BSA technique, while for the BSA-MTP technique, the average BER is 0.0031. Also we observe that using the BSA-MTP technique, the average BER in the CGBF, MF, and MRC

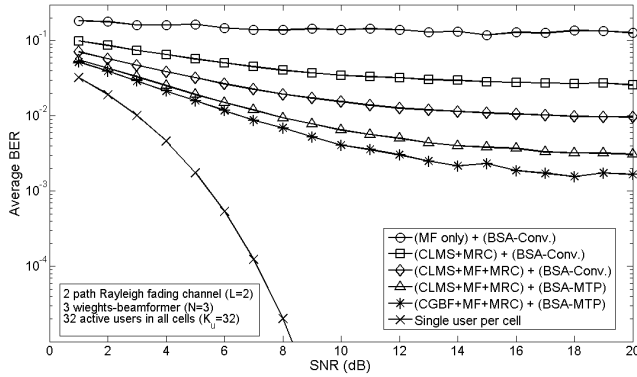

Figure 3. Average BER of all users versus the SNR for the PPC case and $K_u = 32$.

receiver is lower than the CLMS, MF, and MRC receiver. Also, it is clear that the MAI is not removed totally and the performance is still worse than the single user per cell bound.

Fig. 4 shows the average BER versus the number of active users (K_u) for different receivers as Fig. 3, in the case of the PPC and SNR = 10dB. At a BER of 0.005, the three-stage RAKE receiver (CLMS algorithm in the first stage) for the BSA-MTP technique support $K_u = 29$ users, while for the conventional BSA technique support $K_u = 18$ users. We also observe that this receiver can achieve lower BER than the one and two-stage receivers. Also at a BER of 0.002, the three-stage RAKE receiver for the CGBF algorithm in the first stage and for the BSA-MTP technique support $K_u = 24$ users, while the CLMS, MF, and MRC receiver support $K_u = 18$ users.

VII. CONCLUSIONS

In this paper, we studied the RAKE receiver performance of multiple-cell DS-CDMA system with the space diversity processing, Rayleigh frequency-selective channel model, closed-loop power control, and base station assignment. This receiver consists of CLMS algorithm, MF, and MRC in three stages. Accordingly, we proposed the BSA-MTP technique to reduce the CCI and the MAI. It has been shown that, by using antenna arrays at the base stations, the BSA-MTP technique will decrease the interference in all cells. Thus using the proposed technique will decrease the average BER of the system to support a significantly larger number of users.

REFERENCES

- [1] W. Ye and A. M. Haimovich, "Performance of Cellular CDMA with Cell Site Antenna Array, Rayleigh Fading, and Power Control Error," *IEEE Transactions on Communications*, vol. 48, no. 7, pp. 1151-1159, July 2000.
- [2] A. Abrardo and D. Sennati, "On the analytical evaluation of closed-loop power-control error statistics in DS-CDMA cellular systems," *IEEE Transactions on Vehicular Technology*, vol. 49, no. 6, pp. 2071-2080, Nov. 2000.
- [3] L. Carrasco and G. Femenias, "Reverse link performance of a DS-CDMA system with both fast and slow power controlled users," *IEEE Transactions on Wireless Communications*, vol. 7, no. 4, pp. 1255-1263, Apr. 2008.

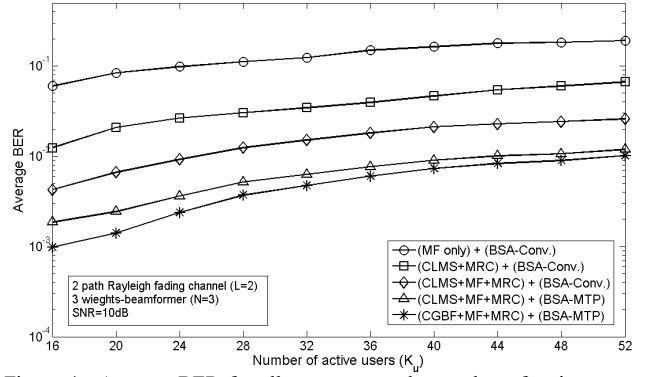

Figure 4. Average BER for all users versus the number of active users (K_u) for the PPC case and SNR = 10dB.

- [4] L. Qian and Z. Gajic, "Variance minimization stochastic power control in CDMA system," *IEEE Transactions on Wireless Communications*, vol. 5, no. 1, pp. 193-202, Jan 2006.
- [5] M. Rintamaki, H. Koivo, and I. Hartimo, "Adaptive closed-loop power control algorithms for CDMA cellular communication systems," *IEEE Transactions on Vehicular Technology*, vol. 53, no. 6, pp. 1756-1768, Nov. 2004.
- [6] J. Wang and A. Yu, "Open-loop power control error in cellular CDMA overlay systems," *IEEE Journal on Selected Areas in Communications*, vol. 19, no. 7, pp. 1246-1254, July 2001.
- [7] J. T. Wang, "Admission control with distributed joint diversity and power control for wireless networks," *IEEE Transactions on Vehicular Technology*, vol. 58, no. 1, pp. 409-419, Jan. 2009.
- [8] M. Dosararian-Moghadam, H. Bakhshi, G. Dadashzadeh, and P. Rahmati, "Adaptive beamforming method based on constrained LMS algorithm for tracking mobile user," *IEEE Global Mobile Congress*, Shanghai, China, Oct. 2009.
- [9] J. Chang, L. Tassiulas, and F. Rashid-Farrokhi, "Joint transmitter receiver diversity for efficient space division multi-access," *IEEE Transactions on Wireless Communications*, vol. 1, no. 1, pp. 16-27, Jan. 2002.
- [10] F. Rashid-Farrokhi, L. Tassiulas, and K. J. Ray-Liu, "Joint optimal power control and beamforming in wireless networks using antenna arrays," *IEEE Transactions on Communications*, vol. 46, no. 10, pp. 1313-1324, Oct. 1998.
- [11] R. D. Yates and C. Huang, "Integrated power control and base station assignment," *IEEE Transactions on Vehicular Technology*, vol. 44, no. 3, pp. 638-644, Aug. 1995.
- [12] S. V. Hanly, "An algorithm for combined cell-site selection and power control to maximize cellular spread spectrum capacity," *IEEE Journal on Selected Areas in Communications*, vol. 3, no. 7, pp. 1332-1340, Sep. 1995.
- [13] M. Mahmoudi and E. S. Sousa, "Joint power control, base station assignment and sectorization for CDMA cellular systems," in *Proc. 2000 IEEE Vehicular Technology Conference*, Boston, MA, vol. 2, pp. 573-580, Sep. 24-28, 2000.
- [14] N. A. Mohamed and J. G. Dunham, "A low-complexity combined antenna array and interference cancellation DS-CDMA receiver in multipath fading channels," *IEEE Journal on Selected Areas in Communications*, vol. 20, no. 2, pp. 248-256, Feb. 2002.
- [15] N. A. Mohamed and J. G. Dunham, "Adaptive beamforming for DS-CDMA using conjugate gradient algorithm in a multipath fading channel," in *Proc. 1999 IEEE Emerging Technologies Symp.*, Dallas, TX, pp. 859-863, Apr. 12-13, 1999.
- [16] F. Rashid-Farrokhi, K. J. Ray-Liu, and L. Tassiulas, "Transmit beamforming and power control for cellular systems," *IEEE Journal on Selected Areas in Communications*, vol. 16, no. 8, pp. 1437-1450, Oct. 1998.
- [17] J. Litva and T. Kwok-Yeung, *Digital Beamforming in Wireless Communications*. Artech-House, 1996.
- [18] S. Xinyu, L. Xiaohua, and Z. Jianjiang, "Robust adaptive beamforming based on maximum likelihood estimation," *International Conference on Microwave and Millimeter Wave Technology*, vol. 3, pp. 1137-1140, April 2008.
- [19] M. Z. Shakir and T. S. Durrani, "Narrowband beamforming algorithm for smart antennas," *International Bhubran Conference on Applied Sciences & Technology*, pp. 49-54, Jan. 2007.
- [20] S. Haykin, *Adaptive Filter Theory*. Prentice Hall, 1996.
- [21] R. L. Peterson, R. E. Ziemer, and D. E. Borth, *Spread-Spectrum Communications*. Prentice-Hall, 1995.