

RESEARCH

Open Access

# Implementation and investigation of circular slot UWB antenna with dual-band-notched characteristics

Abdol Aziz Kalteh<sup>1\*</sup>, Gholamreza DadashZadeh<sup>2</sup> and Mohammad Naser-Moghadasi<sup>1</sup>

## Abstract

The design and analysis of an ultra wideband aperture antenna with dual-band-notched characteristics are presented. The proposed antenna consists of a circular ring exciting stub on the front side and a circular slot on the back ground plane. By utilizing a parasitic strip and a T-shaped stub on the antenna structure, two notched bands of 850 MHz (3.5-4.35 GHz) and 900 MHz (5.05-5.95 GHz) are achieved. The proposed antenna is fabricated and measured. Measured results show that this antenna operates from 2.3 GHz to upper 11 GHz for voltage standing wave ratio less than 2, except two frequency notched bands of 3.5-4.35 and 5.05-5.95 GHz. Moreover, the experimental results show that proposed antenna has stable radiation patterns and constant gain. A conceptual circuit model, which is based on the measured impedance of the proposed antenna, is also shown to investigate the dual-band-notched characteristics.

**Keywords:** ultra-wideband antennas, microstrip slot antennas, band-notched antennas

## 1. Introduction

Since the Federal Communications Commission (FCC) first approved rules for the commercial use of ultra wideband (UWB) in 2002 [1], the feasible design and implementation of UWB system has become a highly competitive topic in both academy and industry communities of telecommunications. Antennas are the particularly challenging aspect of UWB technology. To satisfy such a requirement, various wideband antennas have been studied [2-5]. Challenges of the feasible UWB antenna design include the UWB performances of the impedance matching and radiation stability, the compact appearance of the antenna size, and the low manufacturing cost for consumer electronics applications [6]. The UWB communication systems use the 3.1-10.6 GHz frequency band, unfortunately there are some other existing narrowband services that already occupy frequencies in the UWB band, such as the C-band (3.7-4.2 GHz) satellite communication systems and wireless local-area network (WLAN) IEEE802.11a and HIPERLAN/2

WLAN operating in the 5.15-5.825 GHz band. Therefore, UWB communication systems may cause unwanted interference with other co-existing communication systems. To overcome problems caused by this electromagnetic interference, various UWB antennas with single or multiple notch functions have been developed for UWB communication systems [7-14].

In this article, based on designs presented in [5,10], a circular slot UWB antenna with dual-band-notched characteristics is presented. The proposed antenna composed of circular ring exciting stub on the front side and a circular slot on the back ground plane. To achieve dual-band-notched characteristics at frequency band of WLAN and C-band satellite communication systems, a parasitic semi-circular annular strip and a T-shaped stub are utilized on the antenna structure, respectively. Effects of varying the parameters of the notch functions on performance of antenna have also been studied. Performance simulations of the antenna were performed with Ansoft HFSS10.0 and CST Microwave Studio 5.0 software [15,16].

A conceptual circuit model, which is based on the measured impedance of the proposed antenna, is also shown for investigating the dual-band-notched characteristics. Designed antenna with optimal dimensions was

\* Correspondence: Aziz\_kalteh@yahoo.com

<sup>1</sup>Science and Research Branch, Faculty of Engineering, Islamic Azad University, Tehran, Iran

Full list of author information is available at the end of the article

fabricated and measured. An extensive comparison between experimental and simulation results is made, which demonstrates good agreement over approximately the entire operating frequency range.

The remaining of this article organized as follows: Section 2 presents the configuration of proposed antenna, parametric study of antenna is investigated in Section 3. The simulated and measured results are discussed in Section 4, and finally the conclusion is provided in Section 5.

## 2. Antenna configuration

The geometry of the proposed circular slot UWB antenna possessing band-notched function is depicted in Figure 1, with its geometry parameters. The antenna is located on the  $x$ - $y$  plane and the normal direction is parallel to  $z$ -axis. The proposed antenna is fabricated on

a dielectric substrate of FR4 epoxy substrate with relative permittivity ( $\epsilon_r$ ) of 4.4, thickness of 1.6 mm, and ground plane size of  $L_g \times W_g = 45 \times 40$  mm. For this antenna, the radiation element consists of a circular slot with radius of  $R$ , i.e., fed by a circular ring resonator line with inner and outer radii of  $r_i$  and  $r_o$ , respectively. This ring is connected to the  $50 \Omega$  main line with  $W_f = 3$  mm (see Figure 1a).

To overcome the unwanted electromagnetic interferences of UWB communication systems with IEEE 802.11a and HIPERLAN/2 WLAN and C-band satellite communication systems, a parasitic semicircular annular strip and T-shaped stub are utilized on antenna structure. The parasitic strip is attached to reject the frequency band of WLAN (5.15-5.825 GHz) and T-shaped stub is used to eliminate the frequency band of 3.7-4.2 GHz.

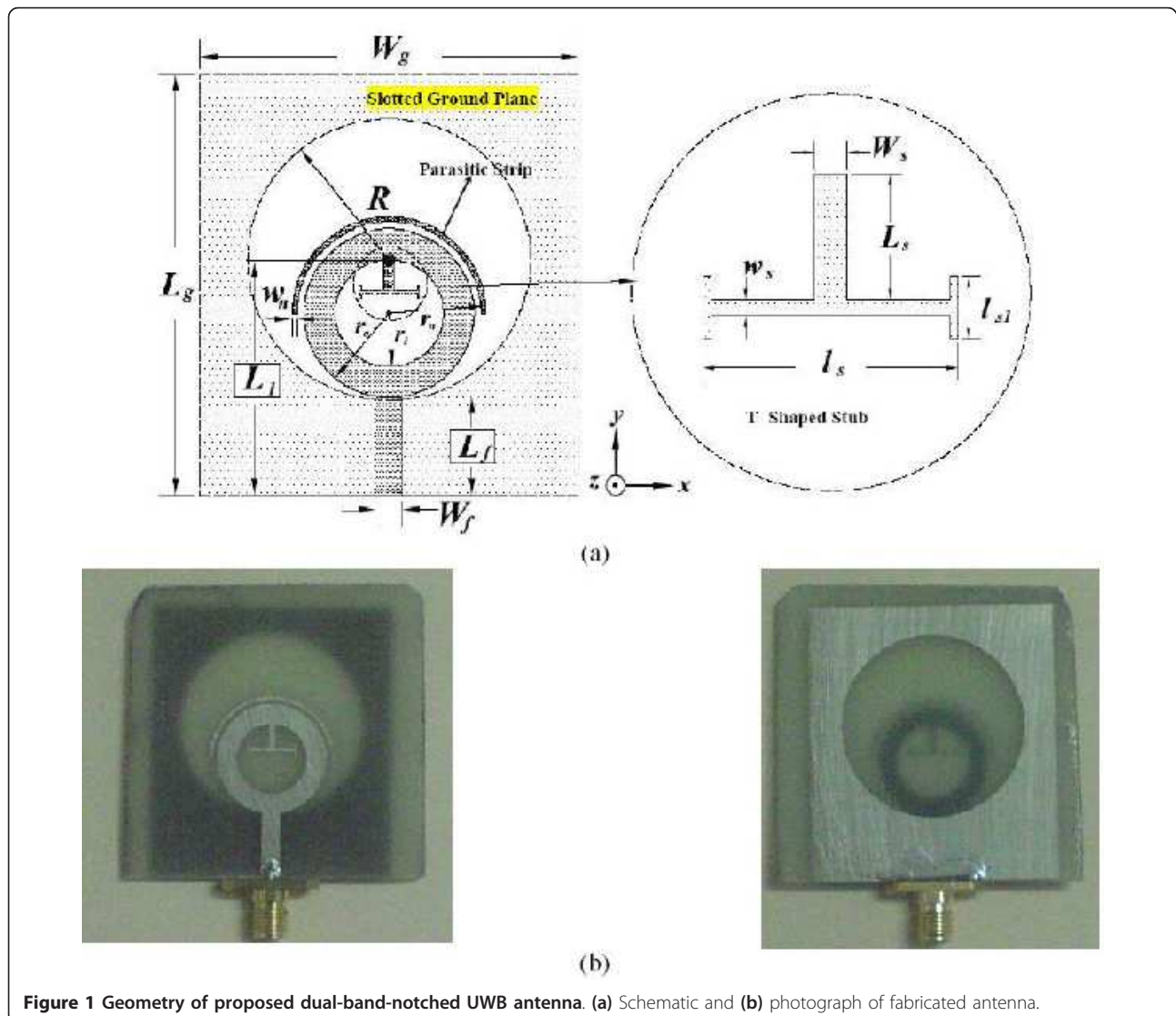

**Figure 1** Geometry of proposed dual-band-notched UWB antenna. (a) Schematic and (b) photograph of fabricated antenna.

### 3. Parametric study of antenna

To achieve the desired band-notched characteristics, the effect of the parasitic annular strip and T-shaped stub parameters on the antenna's performance was studied.

The simulated VSWR of the antenna for different values of  $r_n$  is plotted in Figure 2. This figure shows that by increasing the  $r_n$  the second notching frequency shifts toward lower frequencies and its bandwidth corresponding increases too.

Figure 3 shows the SWR curve of the proposed antenna for different values of  $L_s$ . It can be observed that in this case the first notch's center frequency decreases with the increase of the length of  $L_s$ .

The effect of parameter  $l_s$  of T-shaped stub on the antenna's performance is depicted in Figure 4. It is clear from this figure that the first notched band shifts toward lower frequencies by increasing the length of  $l_s$ .

As observed, the filtering frequencies can be tuned by varying the principal parameters of parasitic annular strip and T-shaped stub.

#### 3.1 VSWR

The simulated and measured VSWR curves of the proposed dual-band-notched UWB antenna, whose dimensions are defined in Table 1 are depicted in Figure 5.

From this figure, we can see that the calculated bandwidth of the proposed antenna for which  $VSWR \leq 2$  is from 2.7 to greater than 10 GHz with two notched frequency bands of 3.5-4.4 GHz (consist of frequency band of C-band satellite communication system) and 5-6 GHz (frequency band of WLAN systems) for  $VSWR \geq 2$ . The measured 3-dB bandwidth of fabricated antenna is from 2.3 to greater than 11 GHz with  $VSWR \leq 2$ , and the notched bandwidths are over 3.5-4.35 and over 5.05-

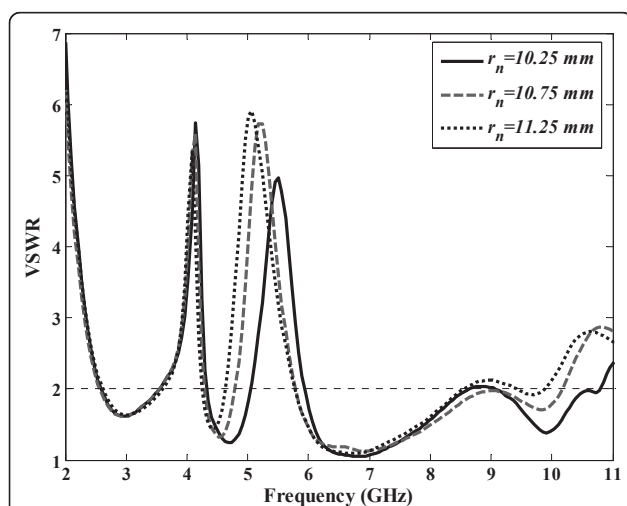

**Figure 2** Effect of  $r_n$  on the antenna's band-notching characteristic.

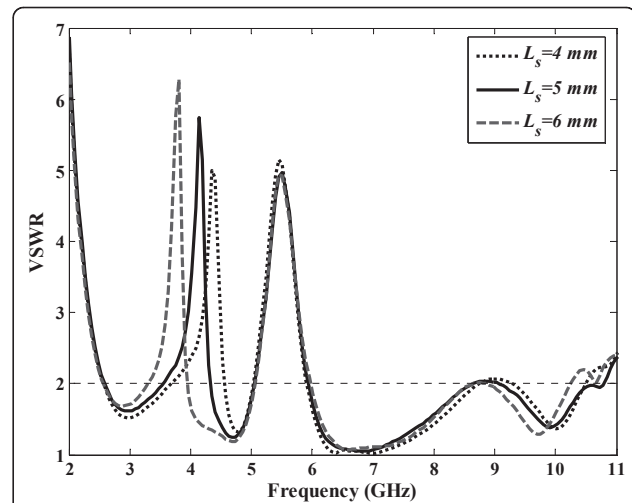
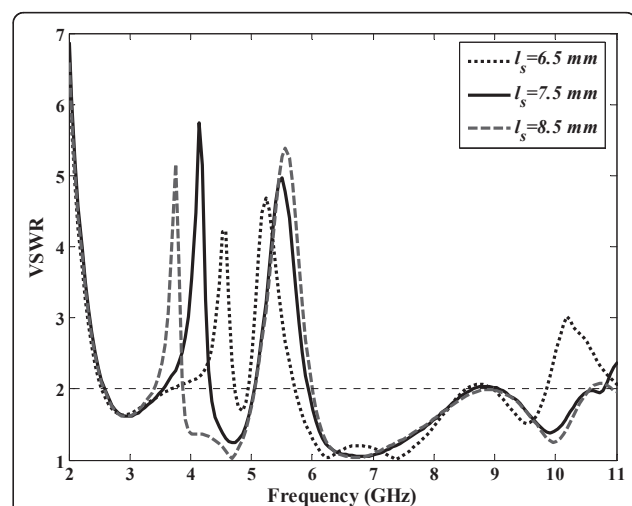

**Figure 3** Effect of parameter  $L_s$  of T-shaped stub on the antenna's band-notching characteristic.

5.95 GHz for  $VSWR \geq 2$ . The measured frequency range encompasses the commercial UWB band (3.1-10.6 GHz), and the notch functions reject the frequency bands of C-band satellite communication and IEEE 802.11a to overcome EMI problems of UWB systems with WLAN and C-band satellite communication systems. The correlation between the numerical and experimental results is considered to be excellent.

#### 3.2 Radiation patterns and gain

The simulated and measured antenna gain in the entire UWB band is presented in Figure 6, which shows sharp gain decreases occur both in 3.6-4.2 and 5-6 GHz bands. However, for other frequencies outside the



**Figure 4** Effect of parameter  $l_s$  of T-shaped stub on the band-notched characteristics.

**Table 1 Dimensions of the proposed UWB antenna**

Parameter	Value (mm)
$W_g$	40
$L_g$	45
$R$	15
$r_o$	9
$r_i$	6
$W_f$	3
$L_f$	10.6
$L_1$	25.2
$L_s$	5
$W_s$	1
$l_{s1}$	7
$l_{s2}$	2
$w_s$	0.5
$r_n$	10.25
$W_n$	0.5

rejected bands, the antenna gain is nearly constant in the entire UWB band.

The measured and simulated radiation patterns of proposed dual-band-notched UWB antenna in the E-plane ( $yz$ -plane) and H-plane ( $xz$ -plane) for three different frequencies 3.3, 7, and 10 GHz are shown in Figure 7. The patterns in the H-plane are quite omni-directional as expected. In the E-plane, the radiation patterns remain roughly a dumbbell-shape like bidirectional patterns.

### 3.3 Input impedance

Figure 8 shows the input impedance curve of the proposed dual-band-notched UWB antenna. In the notched frequency bands, it could be obviously investigated that the imaginary component curve shows parallel

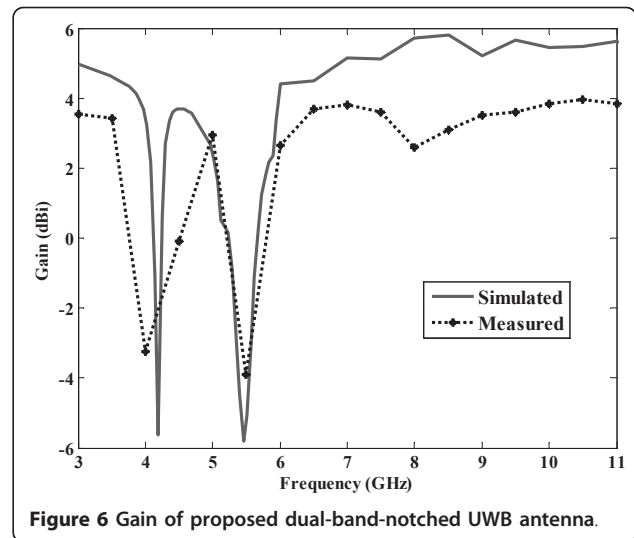
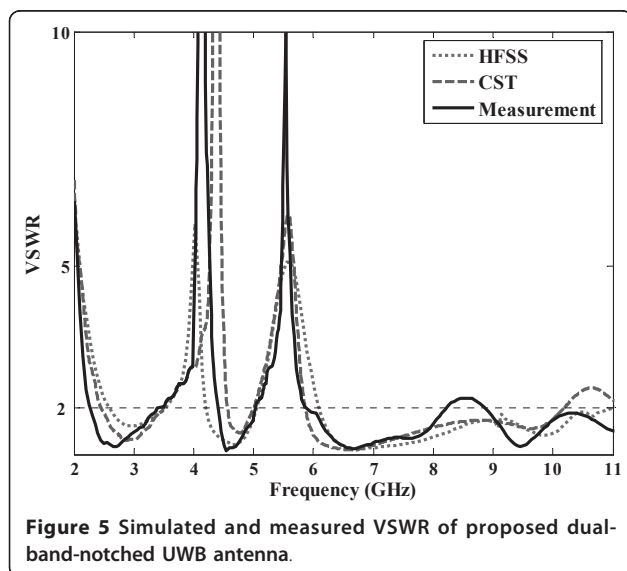

resonances and the real component presents high resistance characteristics. As a result of impedance curve of proposed antenna, it is suggested that the input impedance of the notched antenna is equivalent to the input

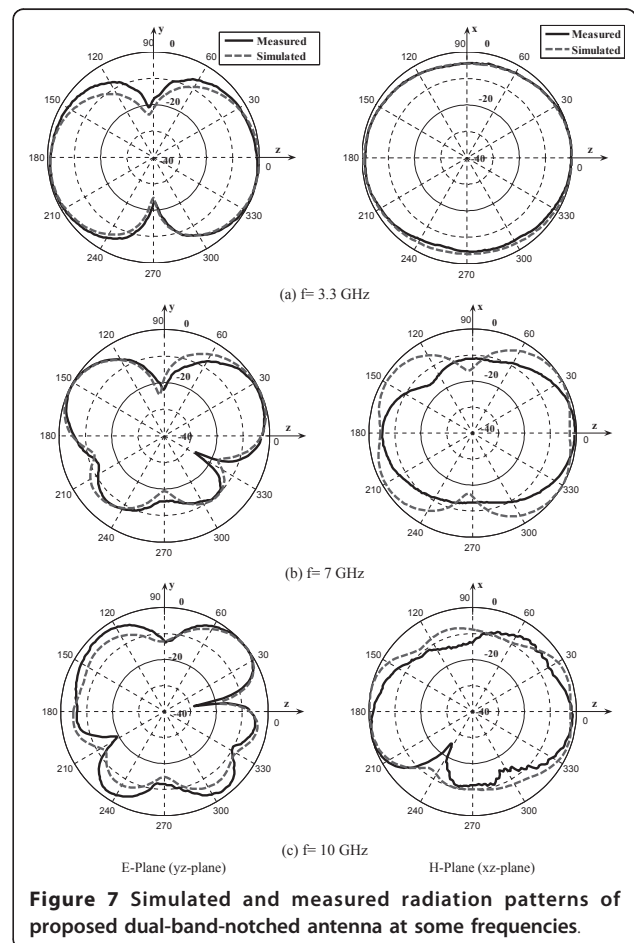

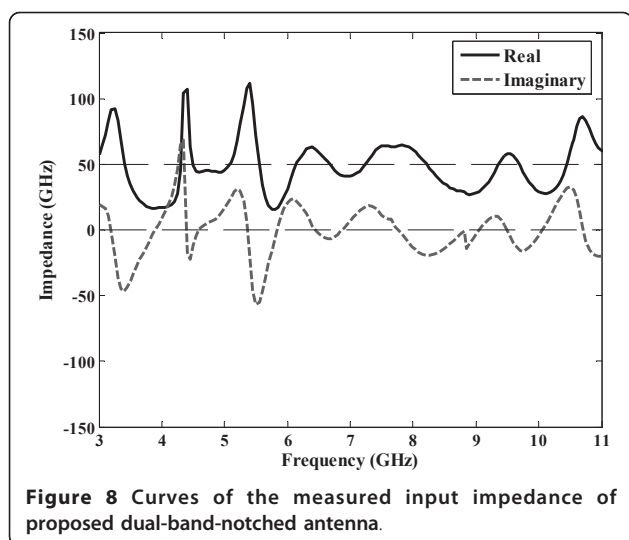

**Figure 8** Curves of the measured input impedance of proposed dual-band-notched antenna.

impedance  $R_a$  of the un-notched reference antenna connected with two parallel LC-resonant circuits in series. The corresponding conceptual circuit model is shown in Figure 9.

When the proposed antenna is operating at the two desired notched frequencies, the two corresponding LC-resonant circuits mentioned above will be syntononic, which leads to the input impedance to be opened. Therefore, proposed band-notched UWB antenna presents high impedance characteristics at notched frequencies.

#### 4. Results and discussions

The simulated and measured results of VSWR, radiation patterns, gain, and input impedance of the proposed antenna are presented in this section. The simulations were performed using Ansoft HFSS and CST Microwave Studio, which utilize numerical methods for electromagnetic computations. The VSWR and input impedance of antenna was measured by the Agilent 8722ES network analyzer and radiation characteristics measurements

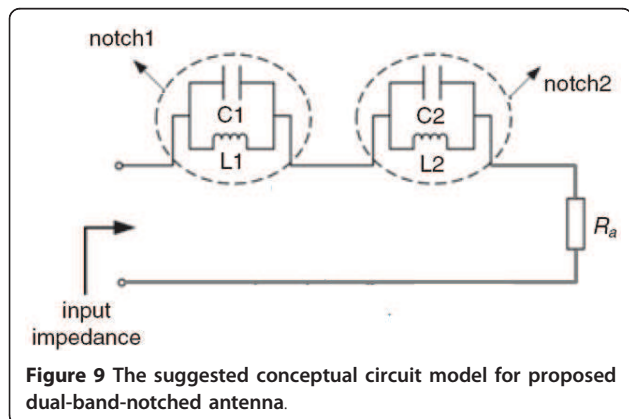

**Figure 9** The suggested conceptual circuit model for proposed dual-band-notched antenna.

were performed in anechoic chamber of antenna laboratory of Iran Research Institute for ICT (ITRC).

#### 5. Conclusion

A circular slot UWB antenna with dual-band-notched characteristics at C-band (3.7-4.2 GHz) satellite communication systems and WLAN frequencies has been proposed and fabricated. The measurements show that VSWR is below 2 within the desired frequency bandwidth from 2.3 to greater than 11 GHz, whereas two notched frequency bands of 3.5-4.35 and 5.05-5.95 GHz for  $VSWR \geq 2$  are obtained. The stable radiation patterns and constant gain in the UWB band, with the exception of notched bands, are obtained. To discuss the mechanism of the filtering properties, a conceptual circuit model based on the dual-band-notched phenomenon has been proposed. Accordingly, the proposed antenna is expected to be a good candidate in various UWB systems.

#### Acknowledgements

The authors would like to thank the Islamic Azad University Science & Research Branch (SRBIU) and Iran Research Institute for ICT (ITRC) for bracing this research.

#### Author details

<sup>1</sup>Science and Research Branch, Faculty of Engineering, Islamic Azad University, Tehran, Iran <sup>2</sup>Department of Electrical Engineering, Faculty of Engineering, Shahed University, Tehran, Iran

#### Competing interests

The authors declare that they have no competing interests.

Received: 23 February 2011 Accepted: 5 September 2011

Published: 5 September 2011

#### References

1. First Report and Order, Revision of Part 15 of the Commission's Rule Regarding Ultra-Wideband Transmission System FCC 02-48, Federal Communications Commission (2002)
2. TG Ma, SK Jeng, Planar miniature tapered-slot-fed annular slot antennas for ultra-wideband radios. *IEEE Trans Antennas Propag.* **53**, 1194-1202 (2005)
3. CY Huang, WC Hsia, Planar elliptical antenna for ultra wideband communications. *Electron Lett.* **41**, 296-297 (2005). doi:10.1049/el:20057244
4. J Liang, CC Chiau, XD Chen, CG Parini, Study of a printed circular disc monopole antenna for UWB systems. *IEEE Trans Antennas Propagat.* **53**(11), 3500-3504 (2005)
5. P Li, J Liang, X Chen, Study of printed elliptical/circular slot antennas for ultra-wideband applications. *IEEE Trans Antenna Propagat.* **54**(6), 1670-1675 (2006). doi:10.1109/TAP.2006.875499
6. YC Lin, KJ Hung, Compact ultra wideband rectangular aperture antenna and band-notched designs. *IEEE Trans Antennas Propagat.* **54**, 3075-3081 (2006)
7. AAL Neyestanak, AA Kalteh, Band-notched elliptical slot UWB microstrip antenna with elliptical stub filled by the H-shaped slot. *J Electromag Waves Appl.* **22**(14-15), 1993-2002 (2008)
8. K-H Kim, S-O Park, Analysis of the small band-rejected antenna with the parasitic strip for UWB. *IEEE Trans Antennas Propagat.* **54**(6), 1688-1692 (2006). doi:10.1109/TAP.2006.875911
9. YC Lin, KJ Hung, Compact ultra wideband rectangular aperture antenna and band-notched design. *IEEE Trans Antennas Propagat.* **54**, 3075-3081 (2006)
10. R Fallahi, A-A Kalteh, MG Roozbahani, A novel UWB elliptical slot antenna with band-notched characteristics. *Progress Electromag Res PIER.* **82**, 127-136 (2008)

11. AA Kalteh, R Fallahi, MG Roozbahani, A novel microstrip-Fed UWB circular slot antenna with 5-GHz band-notch characteristics, in *Proceedings of the 2008 IEEE International Conference on Ultra-wideband (ICUWB2008)* **1**, 117–120 (2008)
12. M Naser-Moghadasi, GR DadashZadeh, A-A Kalteh, Bal VirdeeS, Design of a novel band-notched slot patch antenna for UWB communication systems. *Microwave Opt Technol Lett.* **52**(7), 1599–1603 (2010). doi:10.1002/mop.25237
13. YH Zhao, JP Xu, K Yin, Dual band-notched ultra-widebandmicrostrip antenna using asymmetrical spurlines. *Electron Lett.* **44**(18), 1051–1052 (2008). doi:10.1049/el:20081695
14. Q-X Chu, Y-Y Yang, A compact ultrawideband antenna with 3.4/5.5 GHz dual band-notched characteristics. *IEEE Trans Antennas Propagat.* **56**, 3637–3644 (2008)
15. Ansoft High Frequency Structure Simulation (HFSS), Version 10 (Ansoft Corporation, 2005)
16. Computer Simulation Technology (CST) Microwave Studio Software, Version 5.0

doi:10.1186/1687-1499-2011-88

**Cite this article as:** Kalteh et al.: Implementation and investigation of circular slot UWB antenna with dual-band-notched characteristics. *EURASIP Journal on Wireless Communications and Networking* 2011 **2011**:88.

**Submit your manuscript to a SpringerOpen<sup>®</sup> journal and benefit from:**

- Convenient online submission
- Rigorous peer review
- Immediate publication on acceptance
- Open access: articles freely available online
- High visibility within the field
- Retaining the copyright to your article

---

Submit your next manuscript at ► [springeropen.com](http://springeropen.com)

---